

# The Birth of Hadron Duality

David Horn

Tel Aviv University

Bloomington, Indiana, June 2015

# Tools of the Trade in Hadron Physics

Underlying principles (some derived from QFT)

- Analyticity and Unitarity of the S-Matrix
- PCT symmetries
- Isospin, flavor SU(3), quarks

Tools for analysis of scattering amplitudes

- Dispersion relations
- Mandelstam representation
- Resonance dominance at low energies
- Regge poles at high energies

# Isospin

$$|\frac{3}{2}, \frac{3}{2}\rangle = |p, \pi^+\rangle,$$

$$|\frac{3}{2}, \frac{1}{2}\rangle = \frac{1}{\sqrt{3}} [|n, \pi^+\rangle + \sqrt{2} |p, \pi^0\rangle],$$

$$|\frac{3}{2}, -\frac{1}{2}\rangle = \frac{1}{\sqrt{3}} [|p, \pi^-\rangle + \sqrt{2} |n, \pi^0\rangle],$$

$$|\frac{3}{2}, -\frac{3}{2}\rangle = |n, \pi^-\rangle,$$

$$|\frac{1}{2}, \frac{1}{2}\rangle = \frac{1}{\sqrt{3}} [\sqrt{2} |n, \pi^+\rangle - |p, \pi^0\rangle],$$

$$|\frac{1}{2}, -\frac{1}{2}\rangle = \frac{1}{\sqrt{3}} [|n, \pi^0\rangle - \sqrt{2} |p, \pi^-\rangle].$$

# The quark model and flavor SU(3)

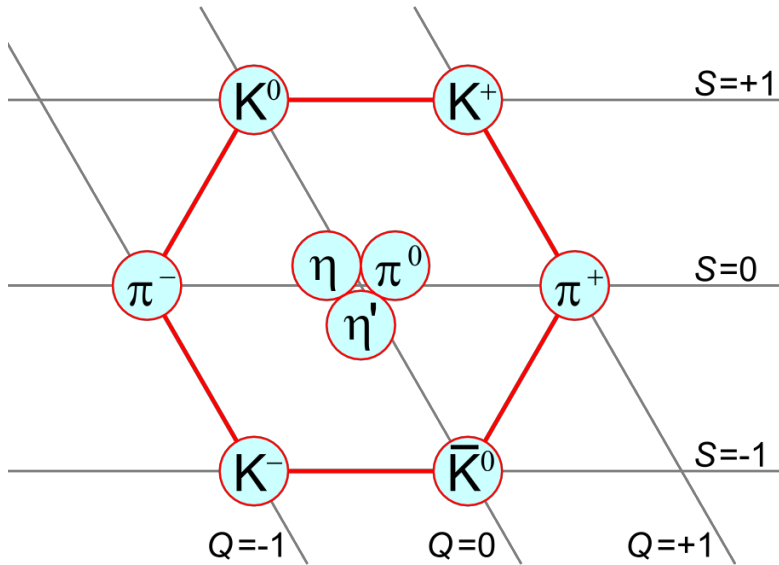

Nonet of pseudoscalar mesons

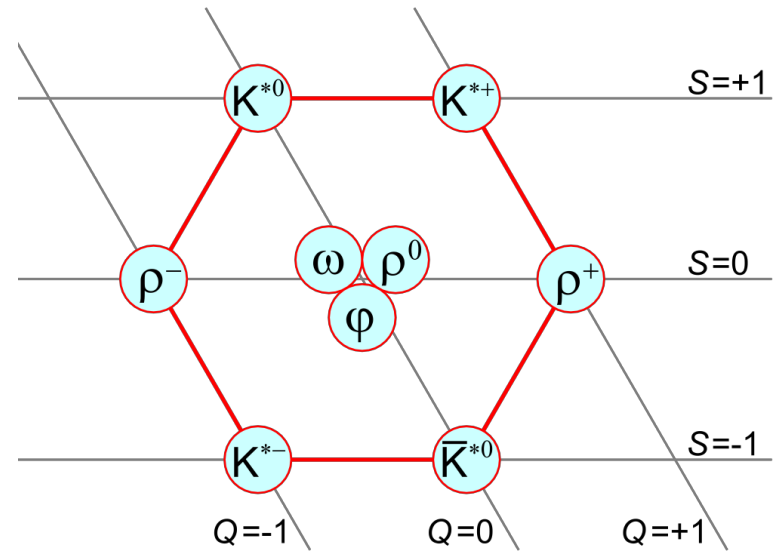

Nonet of vector mesons

# The quark model and flavor SU(3)

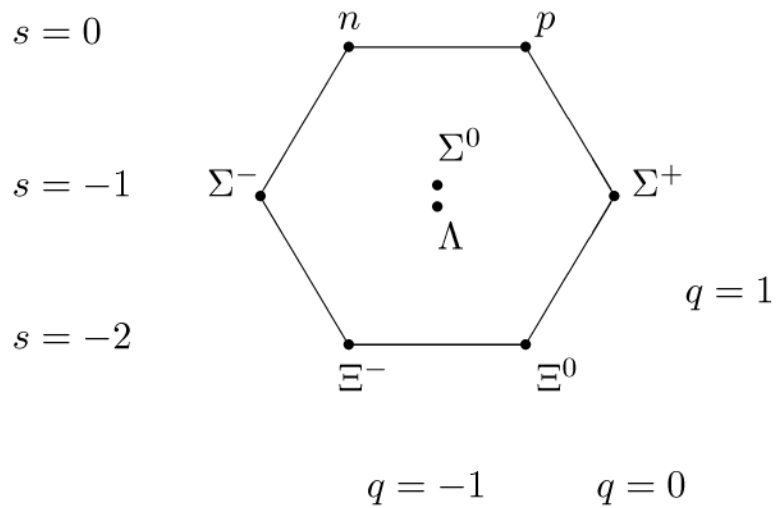

Baryon octet  $J=1/2$

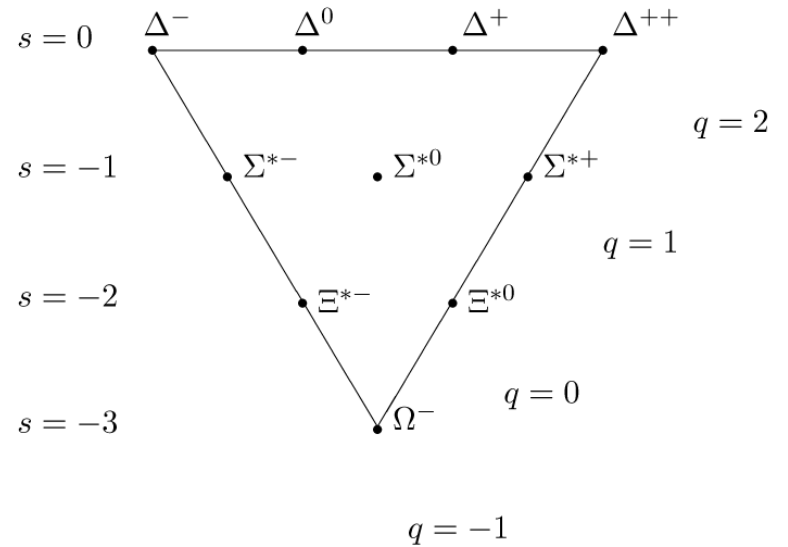

Baryon decuplet  $J=3/2$

# Pion-Nucleon scattering

Four momenta of pions are denoted by  $q$ , of nucleons by  $p$ :  $p_1 + q_1 = p_2 + q_2$

Three independent four-vectors  $P = \frac{1}{2}(p_1 + p_2)$ ,  $Q = \frac{1}{2}(q_1 + q_2)$ ,  $\kappa = \frac{1}{2}(q_1 - q_2)$

Two independent scalars: momentum transfer and lab energy  $\nu_{\text{lab}}$

$$\kappa^2 = \frac{1}{4}(q_1 - q_2)^2 = \frac{1}{2}\mathbf{q}^2(1 - \cos\theta) \quad (\text{in c.m. coordinates}) \quad \nu = -P \cdot Q/M \quad \nu = \nu_L - (\kappa^2/M)$$

Nucleon spinors

$$(i\gamma \cdot p_1 + M)u_1 = 0,$$

$$(i\gamma \cdot p_2 + M)u_2 = 0.$$

S matrix

$$S = \delta_{fi} - (2\pi)^4 i \delta^4(p_2 + q_2 - p_1 - q_1)$$

$$\times \left( \frac{M^2}{4E_1 E_2 \omega_1 \omega_2} \right)^{\frac{1}{2}} \bar{u}_2 T u_1$$

The T-matrix is

$$T = -A + i\gamma \cdot QB$$

A and B are matrices in terms of 3 pion indices

$$A_{\beta\alpha} = \delta_{\beta\alpha} A^{(+)} + \frac{1}{2}[\tau_\beta, \tau_\alpha] A^{(-)}$$

or, with isospin decomposition

$$B_{\beta\alpha} = \delta_{\beta\alpha} B^{(+)} + \frac{1}{2}[\tau_\beta, \tau_\alpha] B^{(-)}$$

+ and - refer to symmetry under crossing of pions, e.g.

$\pi^- p \rightarrow \pi^0 n$  vs  $\pi^0 p \rightarrow \pi^+ n$

which is also  $v \rightarrow -v$

$$A^{(+)} = \frac{1}{3}(A^{(\frac{1}{2})} + 2A^{(\frac{3}{2})}),$$

$$A^{(-)} = \frac{1}{3}(A^{(\frac{1}{2})} - A^{(\frac{3}{2})}), \text{ etc.}$$

Isospin indices refer to direct channel

Taken from Chew et al  
PR 1957

Using center of mass variables

$W =$  total energy,

$E =$  total nucleon energy,

$x = \cos\theta$ .

and nucleon mass  $M$  pion mass  $1$

One can rewrite

$$\frac{1}{4\pi} A^{(\pm)} = \frac{W+M}{E+M} f_1^{(\pm)} - \frac{W-M}{E-M} f_2^{(\pm)},$$

$$\frac{1}{4\pi} B_4^{(\pm)\frac{1}{2}} = \frac{1}{E+M} f_1^{(\pm)} + \frac{1}{E-M} f_2^{(\pm)}.$$

and express the cross-section as

$$\frac{d\sigma}{d\Omega} = \sum \left| \left\langle f \left| f_1 + \frac{\boldsymbol{\sigma} \cdot \mathbf{q}_2 \boldsymbol{\sigma} \cdot \mathbf{q}_1}{q_2 q_1} f_2 \right| i \right\rangle \right|^2$$

summing over final and averaging over initial states.

Partial wave decomposition of amplitudes is

$$f_1 = \sum_{l=0}^{\infty} f_{l+} P_{l+1}'(x) - \sum_{l=2}^{\infty} f_{l-} P_{l-1}'(x)$$

$$f_2 = \sum_{l=1}^{\infty} (f_{l-} - f_{l+}) P_l'(x),$$

where  $f_{l\pm}$  is the scattering amplitude in the state of parity  $-(-1)^l$  and total angular momentum  $j = l \pm \frac{1}{2}$ .  $P_l'(x)$  is the first derivative of the conventionally normalized Legendre polynomial.

Taken from Chew et al  
PR 1957

## Optical theorem and phase shifts

The  $f_{\pm}$  are normalized so that

$$(j + \frac{1}{2}) \operatorname{Im} f_{l_{\pm}} = \frac{q}{4\pi} \sigma_{l_{\pm}}, \quad (2.20)$$

where  $\sigma_{l_{\pm}}$  is the total cross section of the partial wave involved. Thus, for energies below the two-meson threshold,

$$f_{l_{\pm}} = e^{i\delta_{l_{\pm}}} \frac{\sin \delta_{l_{\pm}}}{q}, \quad (2.21)$$

where  $\delta_{l_{\pm}}$  is the real phase shift in the state  $l_{\pm}$ ; above this threshold a representation of the form (2.21) still holds, but with complex  $\delta_{l_{\pm}}$ .



The 33 resonance.  
Fermi first  
discovered it in  
phase-shift analysis.

See Cahn and  
Goldhaber, 1989.

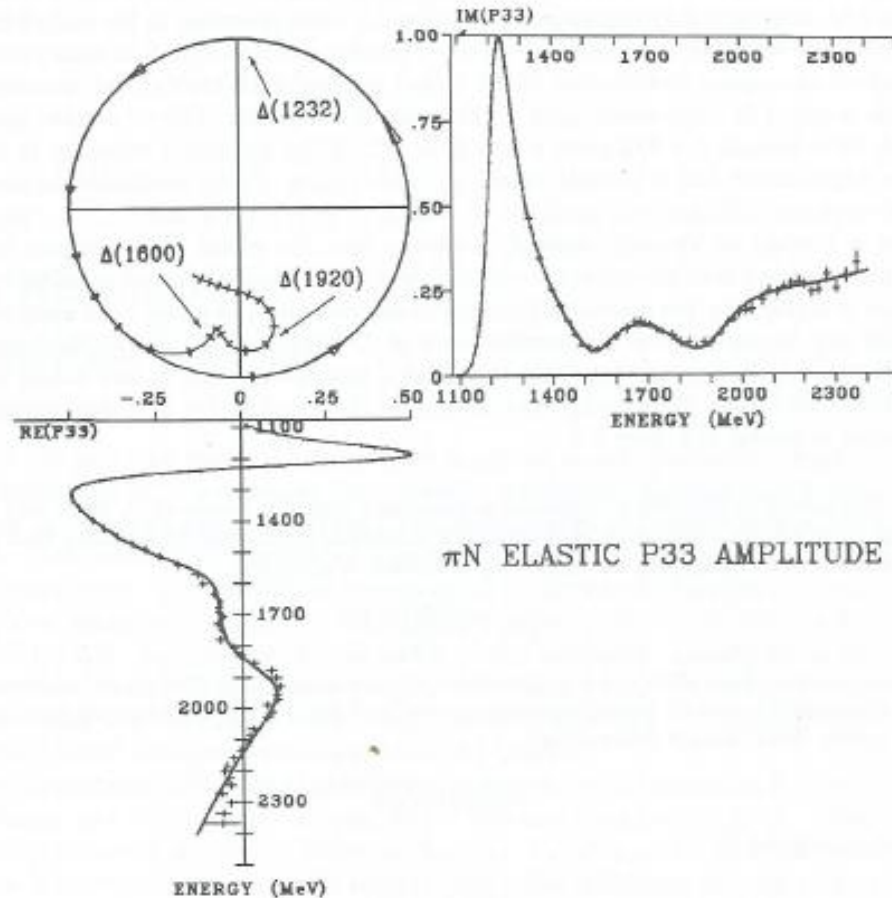

Figure 5.1: An analysis of the  $J = 3/2, I = 3/2$  channel of pion-nucleon scattering. Scattering data have been analyzed and fits made to the various angular momentum and isospin channels. For each channel there is an amplitude,  $a_{IJ} = (e^{i\delta_{IJ}} - 1)/2i$ , where  $\delta_{IJ}$  is real for elastic scattering and  $\text{Im}\delta_{IJ} > 0$  if there is inelasticity. Elastic scattering gives an amplitude on the boundary of the Argand circle, with a resonance occurring when the amplitude reaches the top of the circle. In the Figure, the elastic resonance at 1232 MeV is visible, as well as two inelastic resonances. Tick marks indicate 50 MeV intervals. The projections of the imaginary and real parts of the  $J = 3/2, I = 3/2$  partial wave amplitude are shown to the right and below the Argand circle [Results of R. E. Cutkosky as presented in *Review of Particle Properties, Phys. Lett. 170B, 1 (1986)*].

# What is a resonance?

- A circle in the phase-shift analysis
- A bump in the cross-section
- A Breit Wigner structure
- A pole in the scattering amplitude
- A particle decaying via strong interactions

Or all of the above...

For elastic scattering  $f = \frac{e^{i\delta} \sin\delta}{k}$  where  $k$  is the c.m. momentum, and  $\delta$  is real (when other particle production channels open up it becomes complex).

The Breit-Wigner approximation for a resonance with mass  $M$  and width  $\Gamma$  is

$$f = \frac{e^{i\delta} \sin\delta}{k} = -\frac{1}{k} \frac{\Gamma/2}{E - M + i\Gamma/2}$$

Leading to differential cross section

$$\frac{d\sigma}{d\Omega} = |f|^2$$

and total cross-section

$$\sigma = 4\pi |f|^2 = \frac{4\pi}{k^2} \frac{\Gamma^2/4}{(E - M)^2 + \Gamma^2/4}$$

# Dispersion Relations

Assume the scattering amplitude is an analytic function with a cut along the real axis (and possibly one or two poles). In this case, the Cauchy contour integral

$$f(s) = \frac{1}{2\pi i} \oint \frac{f(s') ds'}{s' - s}$$

turns into the following expression along the real axis

$$f(s) = \frac{1}{\pi} \int_0^\infty ds' \frac{\text{Im} f(s')}{s' - s - i\epsilon} + \frac{c}{s_0 - s}$$

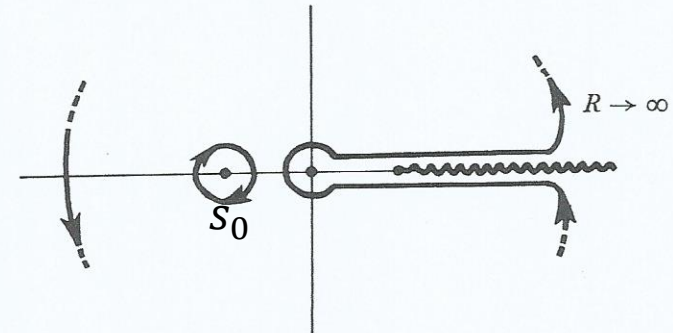

provided  $f(s)$  declines appropriately on the infinite circle. This follows because the discontinuity along the cut is proportional to the imaginary part. It can also be rewritten as

$$\text{Re} f(s) = \frac{1}{\pi} P \int_0^\infty \frac{ds'}{s' - s} \text{Im} f(s')$$

employing the equality

$$\frac{1}{x - x_0 - i\epsilon} = P \frac{1}{x - x_0} + i\pi \delta(x - x_0)$$

Although we omitted the pole at  $s_0$  we should implicitly remember it as part of the integral.

# Subtracted Dispersion Relations

$$f(s) = \frac{1}{\pi} \int_0^{\infty} ds' \frac{\text{Im}f(s')}{s' - s - i\epsilon}$$

If  $\text{Im}f(s)$  does not decrease fast enough for large  $s$ , one may invoke the subtracted dispersion relation

$$f(s) - f(0) = \frac{1}{\pi} \int_0^{\infty} ds' \frac{s \text{Im}f(s')}{s'(s' - s - i\epsilon)}$$

If, on the other hand,  $f(s)$  decreases faster than  $1/s$  then it obeys the “superconvergence relation”

$$\int_0^{\infty} \text{Im}f(s) ds = 0$$

# Dispersion relations in $\pi N$ scattering

$$\begin{aligned} \operatorname{Re}A^{(\pm)}(\nu, \kappa^2) &= -\frac{P}{\pi} \int_{1-\kappa^2/M}^{\infty} d\nu' \operatorname{Im}A^{(\pm)}(\nu', \kappa^2) \left( \frac{1}{\nu' - \nu} \pm \frac{1}{\nu' + \nu} \right) \\ \operatorname{Re}B^{(\pm)}(\nu, \kappa^2) &= \frac{g_r^2}{2M} \left( \frac{1}{\nu_B - \nu} \mp \frac{1}{\nu_B + \nu} \right) \\ &+ \frac{P}{\pi} \int_{1-\kappa^2/M}^{\infty} d\nu' \operatorname{Im}B^{(\pm)}(\nu', \kappa^2) \left( \frac{1}{\nu' - \nu} \mp \frac{1}{\nu' + \nu} \right) \end{aligned}$$

where the poles below threshold represent the nucleon state i.e.  $\pi N \rightarrow N \rightarrow \pi N$

$$\nu_B = -(1/2M) - (\kappa^2/M) \quad g_r^2/4\pi \approx 14.$$

# Mandelstam representation

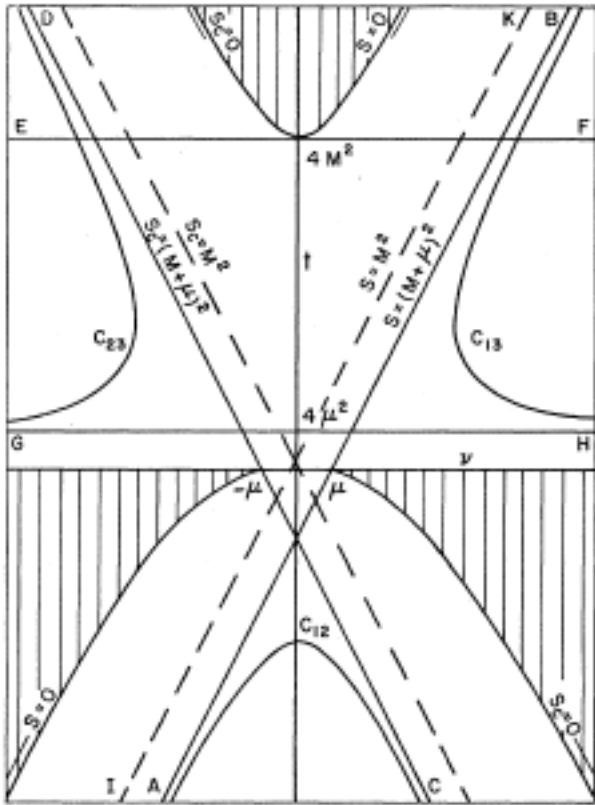

S-matrix models of two-to-two particle-scattering are described in terms of the  $s, t, u$  Mandelstam variables  $s=(p_1+p_2)^2=(p_3+p_4)^2$ ,  $t=(p_1-p_3)^2=(p_2-p_4)^2$ , and  $u=(p_1-p_4)^2=(p_3-p_2)^2$ , obeying the over-all constraint  $s+t+u=\sum_i m_i^2$ . The physical region for the process  $1+2 \rightarrow 3+4$  is characterized by positive  $s$  and negative  $t$ . Physical regions in the crossed channels described processes involving the anti-particles, according to conventional associations in Feynman diagrams.

The Mandelstam plot for  $\pi N$  scattering, taken from the original paper [1958]. Masses of  $\pi$  and  $N$  are denoted by  $\mu$  and  $M$ , respectively. The physical region of  $s$  is the shaded region on the bottom right.

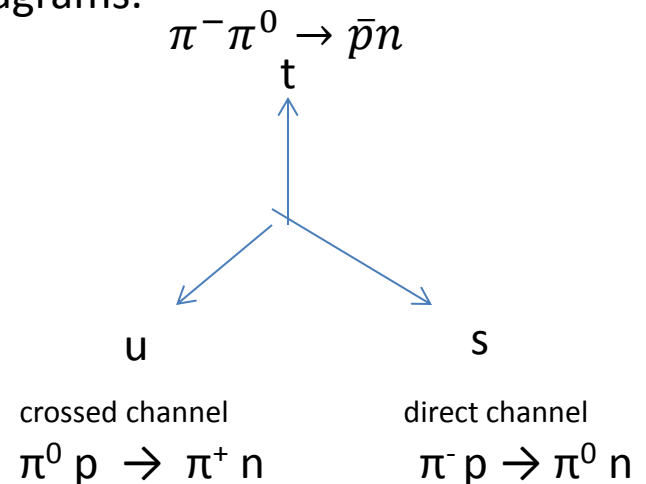

$$t \geq 4M^2$$

$$s \leq 0$$

$$u \leq 0$$

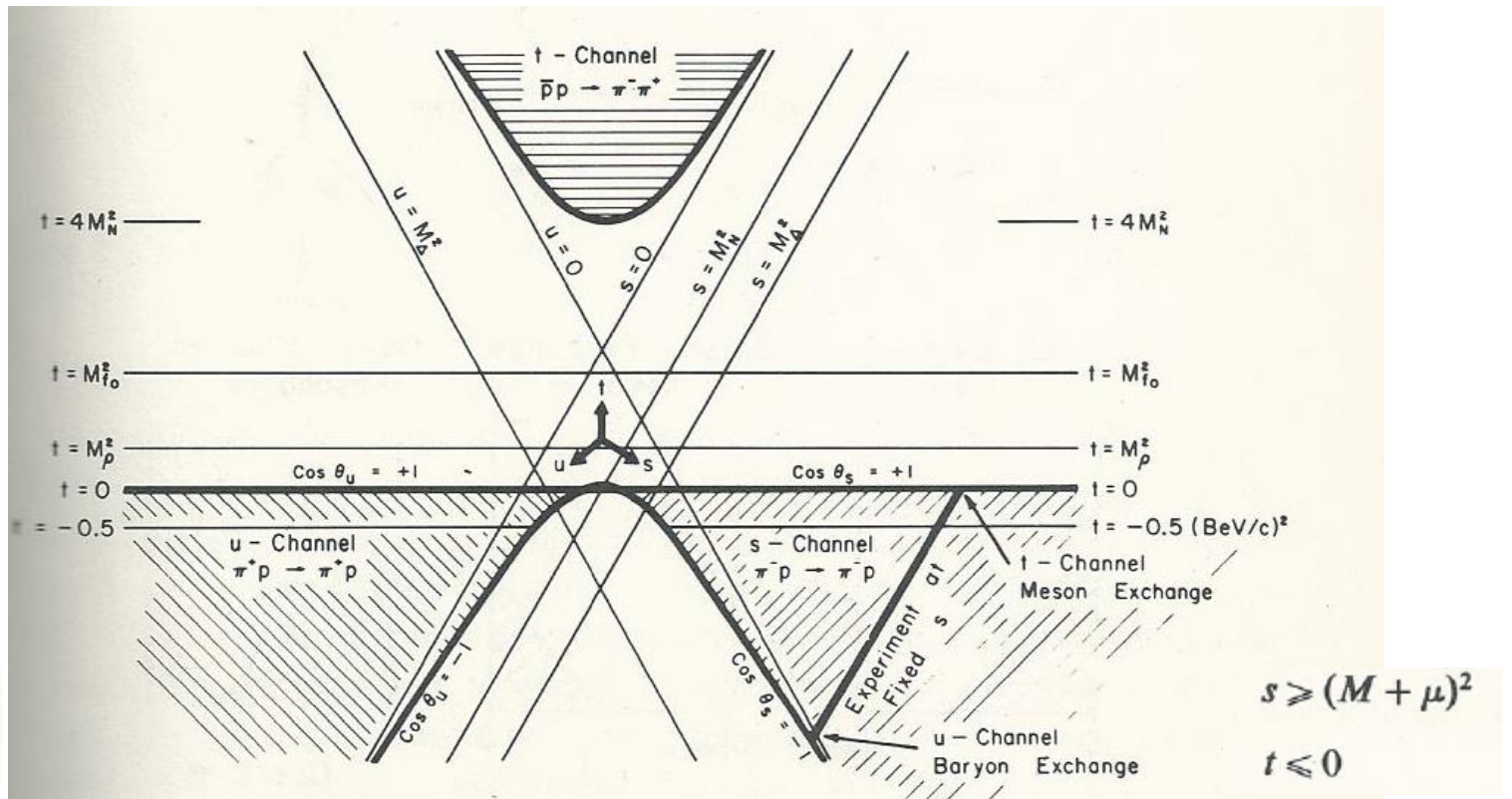

$$u \geq (M + \mu)^2$$

$$t \leq 0$$

$$s \geq (M + \mu)^2$$

$$t \leq 0$$

$$s = M^2 + \mu^2 + 2ME_{\text{Lab}}$$

$$t = -2k^2(1 - \cos \theta_s)$$

From Barger and Cline 1969

Scattering Angle  $\theta$

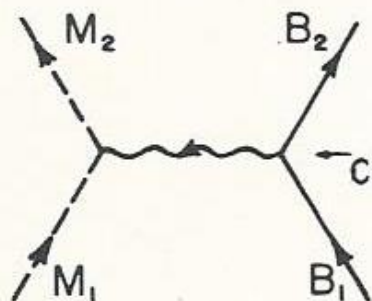
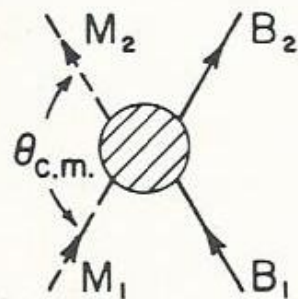

t Channel

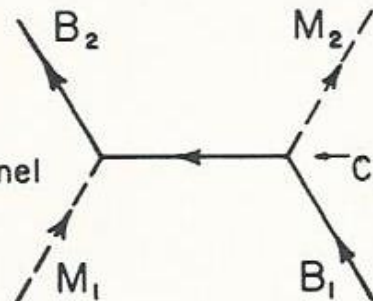

u Channel



s Channel

Meson Exchange

$\cos \theta \rightarrow$

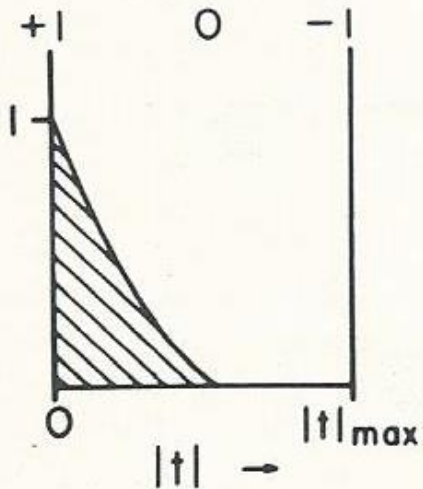

Baryon Exchange

$\cos \theta \rightarrow$

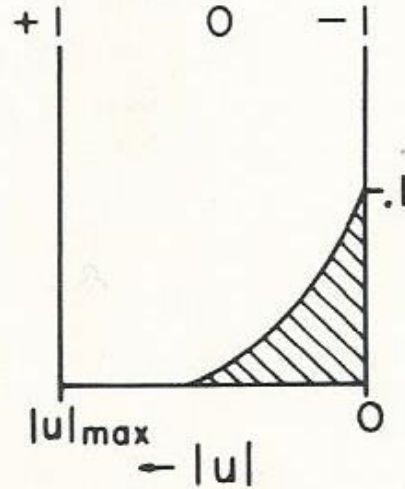

Direct Channel Resonance

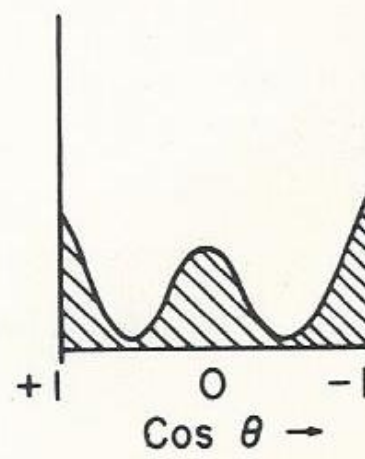



# Regge Poles in the t-channel

Regge introduced the concept of Regge-poles in complex  $J$  (1959, 1960). A Regge-pole  $\alpha(t)$ , associated with some given quantum numbers (isospin, baryon number, strangeness) interpolates between particles of mass  $m$  such that  $\text{Re}\alpha(t=m^2)=J$ , the spin of the particle.

Regge poles are conjectured to influence the scattering amplitude at high energies (large  $s$  and  $t \leq 0$ ) in a fashion associated with the behavior of  $\alpha$  at these values, as  $s^{\alpha(t)}$  with the trajectories being approximately linear (Chew and Frautschi 1962), as seen in the figure taken from their paper.

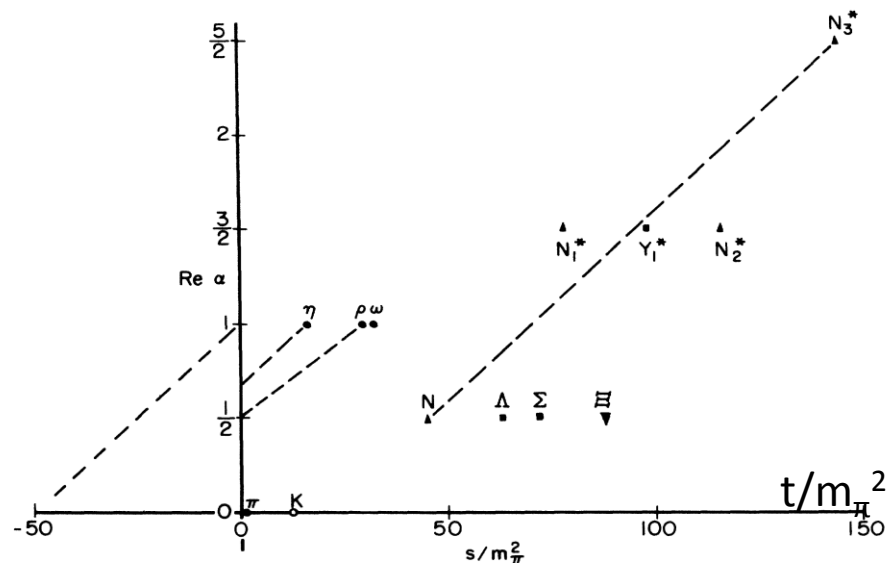

## Naïve construction of Regge exchange

Consider the contribution of the Feynman diagram of the exchange of a single particle in the t-channel at large s

$$F(s, t) = \frac{g_J^2 [-(s/s_0)]^J}{M_J^2 - t} \quad s \rightarrow \infty$$

Now assume there exists a Regge trajectory with an infinite tower of particles with spins  $J=1,3,5,\dots$  (known as signature  $\tau=-1$ ).

This will lead to

$$F(s, t) = \sum_{J=0}^{\infty} \frac{g_J^2}{M_J^2 - t} \left[ \frac{(-1)^J - 1}{2} \right] \left( \frac{s}{s_0} \right)^J$$

(in general  $\tau=(-1)^J$  for mesons)

If all have the same coupling, and the trajectory is linear

$$M_J^2 = \mu^2 (J - a)$$

this leads to the Regge amplitude expression

$$F(s, t) = -\frac{g^2 \pi [1 - e^{-i\pi\alpha}]}{2\mu^2 \sin \pi\alpha} \left( \frac{s}{s_0} \right)^\alpha$$

# Regge Poles in the t-channel

Regge introduced the concept of Regge-poles in complex  $J$  (1959, 1960). A Regge-pole  $\alpha(t)$ , associated with some given quantum numbers (isospin, baryon number, strangeness) interpolates between particles of mass  $m$  such that  $\text{Re}\alpha(t=m^2)=J$ , the spin of the particle.

Regge poles are conjectured to influence the scattering amplitude at high energies (large  $s$  and  $t \leq 0$ ) in a fashion associated with the behavior of  $\alpha$  at these values, as  $s^{\alpha(t)}$  with the trajectories being approximately linear (Chew and Frautschi 1962), as seen in the figure taken from their paper.

Consistency with accepted lore:

- $\sigma_T$  cannot increase as a power of  $s$ .  
Since  $\sigma_T \sim s^{\alpha(0)-1}$  it follows that  $\alpha(0) \leq 1$ .
- Trajectory passing through 1 is the Pomeron, implementing Pomeranchuk theorem (equal asymptotic  $\sigma_T$  for particles and anti-particles).
- Note that the Pomeron has no resonances associated with it.

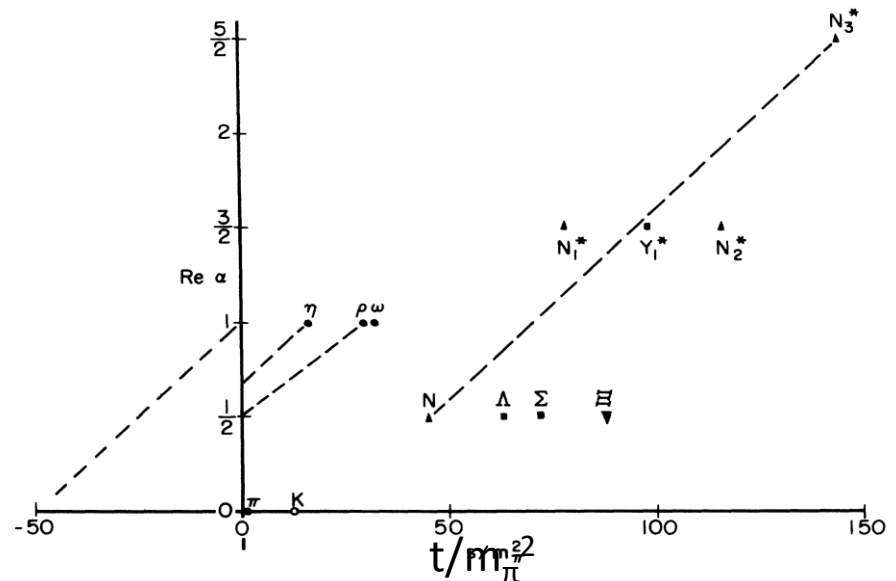

## Chew and Frautschi 1962:

The evidence, of course, lies in the fact that total cross sections actually appear to approach constants at high energy, implying an imaginary part of forward amplitudes  $\propto E_{\text{lab}}$ ; so we have conjectured that a Regge pole with the quantum numbers of the vacuum is responsible—with a trajectory such that  $\alpha_{\text{vac}}(s=0)=1$ .<sup>2</sup> The slope of this vacuum trajectory is expected to be positive at low  $s$  (and similar in order of magnitude to the slopes of other trajectories), and it was explained in the previous Letter and is amplified below why it is plausible to have the vacuum trajectory lie above all others.<sup>2</sup> Thus the condition  $\alpha_{\text{vac}}(s=0)=1$  represents a saturation of Froissart's limit.  $\sigma_T < \log^2(s)$

Differences of total cross-sections can be associated with lower lying Regge poles, such as the  $\rho$

$$\sigma_T(\pi^- p) - \sigma_T(\pi^+ p) \sim s^{\alpha_{\rho(0)}-1}$$

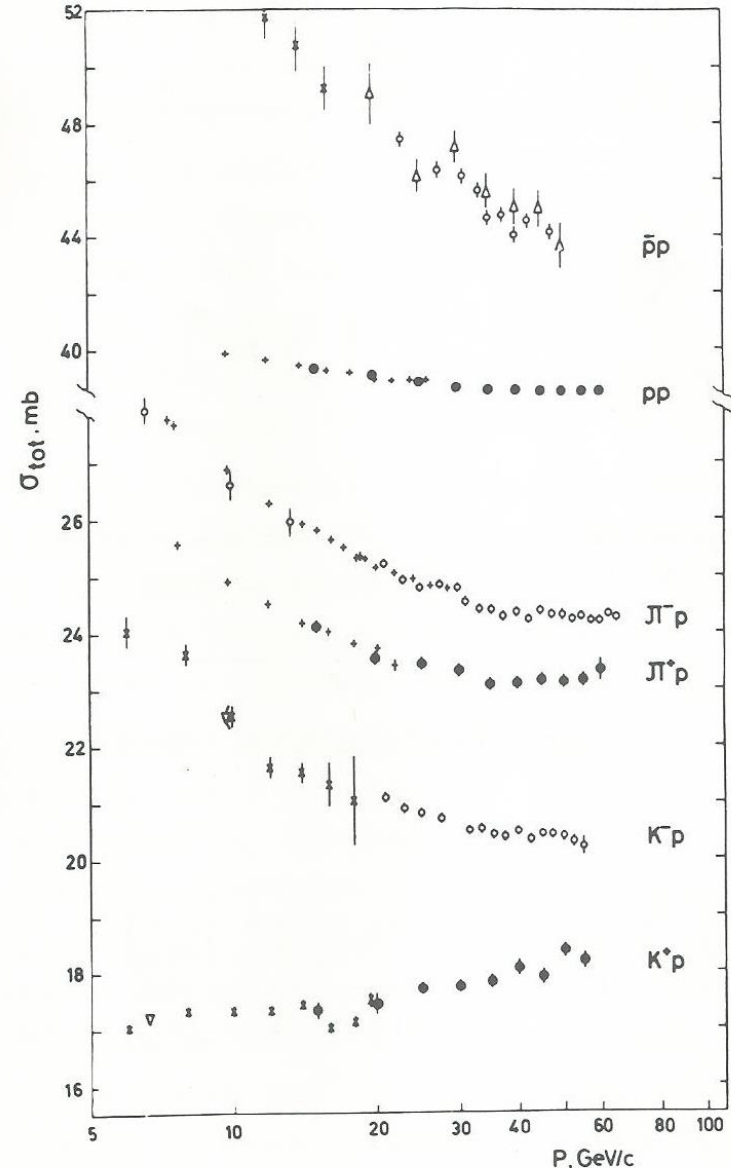

The rich set of analyticity and unitarity constraints has led Chew and Frautschi to propose the **Nuclear Bootstrap** idea, stating that these constraints may suffice to determine a unique set of poles (i.e. particles and resonances) in all channels, thus providing the basis of a theory of the strong interactions.

Thus particle (or Regge-pole) exchanges in the t-channel should be viewed as providing the force which leads to binding particles in the s-channel.

# Resonances and Regge exchanges in $\pi\pi$ scattering

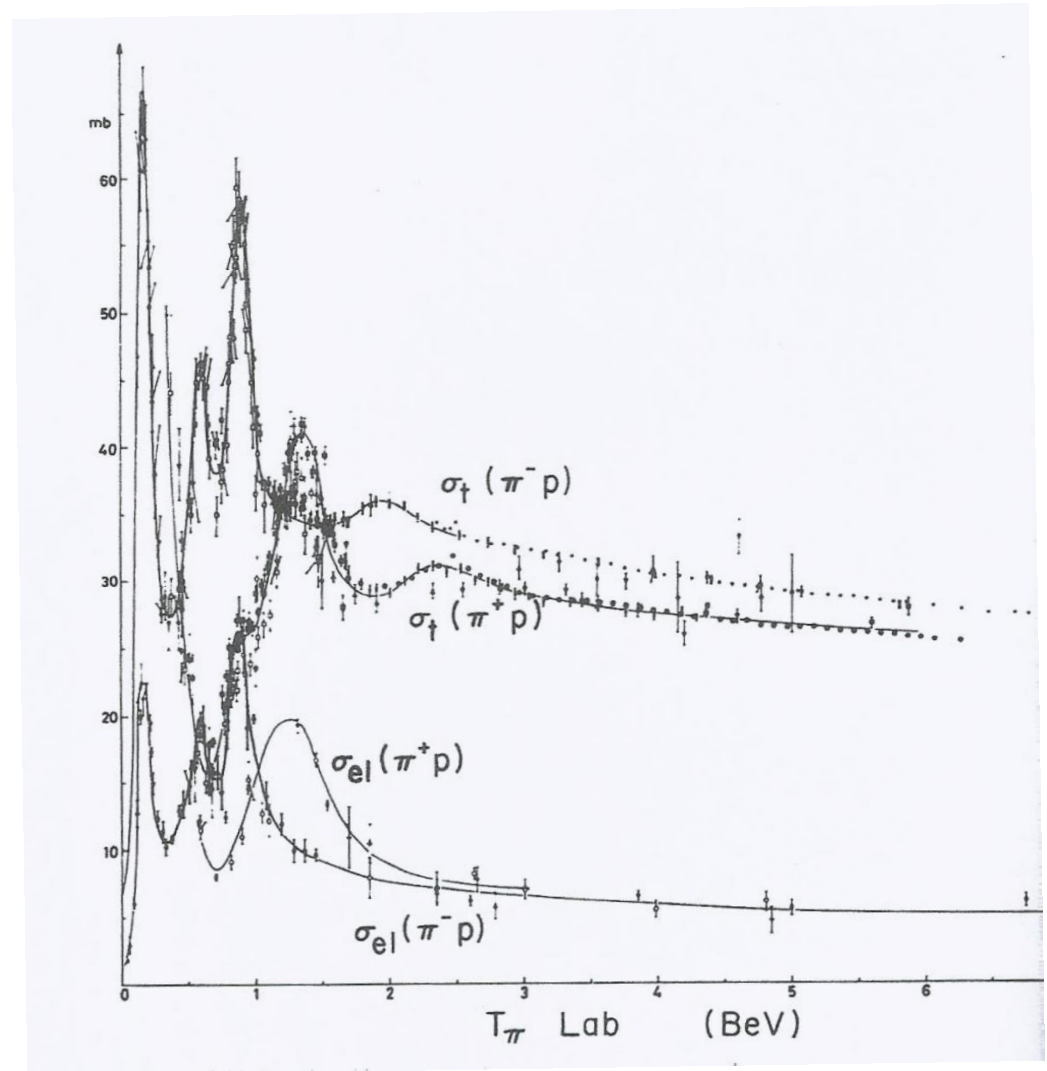
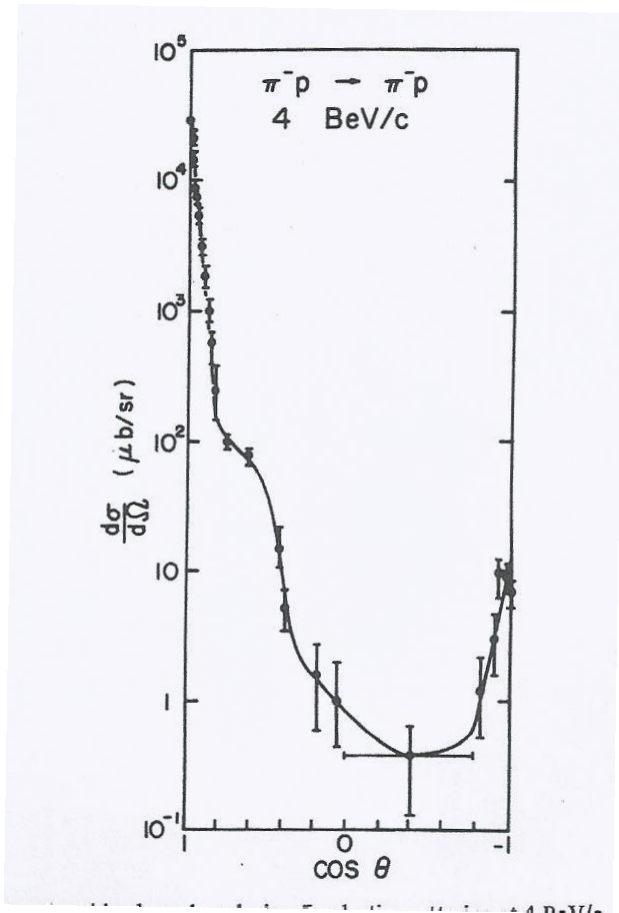

# Charge exchange processes

$$A(\pi^- p \rightarrow \pi^0 n) = \frac{1}{\sqrt{2}} [A(\pi^+ p) - A(\pi^- p)]$$

$$A(K^- p \rightarrow \bar{K}^0 n) = [A(K^- p) - A(K^- n)]$$

$$A(K^+ n \rightarrow K^0 p) = [A(K^+ p) - A(K^+ n)]$$

$$A(\bar{p} p \rightarrow \bar{n} n) = [A(\bar{p} p) - A(\bar{p} n)]$$

$$A(p n \rightarrow n p) = [A(p p) - A(p n)]$$

Note sharp decline with  $t$   
and zero occurring at  $t = -.15$

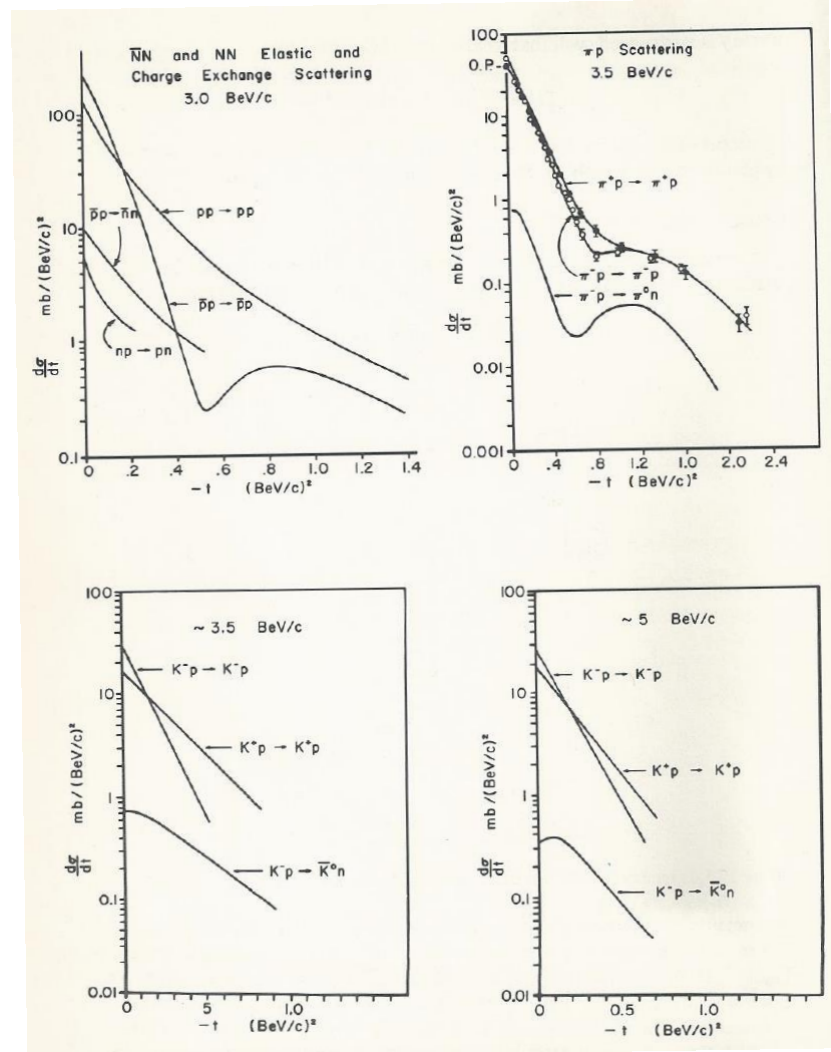

## Candidate Regge exchanges

label	Resonance mass	J,P	I,G	Signature $\tau$	Flavor SU(3)
Pomeron				1	singlet
f,f'	1250, 1500	2+	0+	1	T nonet
A2	1320	2+	1-	1	T nonet
$\omega$	783	1-	0-	-1	V nonet
$\phi$	1020	1-	0-	-1	V nonet
$\rho$	750	1-	1+	-1	V nonet

Using the optical theorem define Regge contributions to total cross-sections

$$\sigma_t(s) = \frac{4\pi}{q_{cm}} \text{Im} f(s, t=0)$$

$$\Delta(AB) = \sigma_t(\bar{A}B) - \sigma_t(AB)$$

e.g. evaluating the contribution of the  $\rho$  Regge trajectory to different scattering amplitudes:

$$\rho_\pi = \frac{3}{2} \Delta(\pi^+ p)$$

$$\rho_K = \frac{3}{2} [\Delta(K^+ p) - \Delta(K^+ n)]$$

$$\rho_N = \frac{3}{2} [\Delta(pp) - \Delta(pn)]$$



# Finite Energy Sum Rules

Consider an anti-symmetric amplitude which obeys an unsubtracted dispersion relation

$$F(v) = \frac{2v}{\pi} \int_0^{\infty} \frac{\text{Im}F(v') dv'}{v'^2 - v^2}$$

Assume it is dominated at high energies by the Regge pole

$$R(v) = \frac{\beta(1 - e^{-i\pi\alpha})}{\sin(\pi\alpha)\Gamma(\alpha + 1)} v^\alpha \quad \text{obeying} \quad R(v) = \frac{2v}{\pi} \int_0^{\infty} \frac{\beta}{\Gamma(\alpha + 1)} \frac{v'^\alpha}{v'^2 - v^2} dv'$$

for  $-1 < \alpha < 1$ . It follows then that their difference obeys a superconvergence relation  $\int_0^{\infty} \text{Im}(F - R) dv = 0$ .

If there exist a few Regge poles above  $-1$ , one can subtract all of them to obtain the superconvergence relation.

# Finite Energy Sum Rules

Consider the case when the Cauchy contour is drawn at the finite circle  $|v|=N$  rather than at infinity. The analog of the dispersion relation becomes

$$\frac{1}{N} \int_0^N \text{Im } F d\nu = \sum_{\alpha} \frac{\beta N^{\alpha}}{\Gamma(\alpha + 2)}$$

where the right-hand-side represents a sum over all Regge poles. There are various advantages for this representation:

- All Regge poles enter irrespective of lying above or below -1
- Their relative importance is the same as in the expansion of F
- One can try and choose N such that for  $\nu < N$  one may insert the data in the form of resonances (or phase-shift analysis), and for  $\nu > N$  the asymptotic expansion in terms of Regge poles provides a good approximation to F.

In fact, one may derive a set of n-moment sum-rules which should hold as well:

Horn and Schmid, Caltech preprint 1967.  
Dolen Horn and Schmid, PRL 1967, PR 1968.

$$S_n(N) = \frac{1}{N^{n+1}} \int_0^N \nu^n \text{Im } F d\nu = \sum_{\alpha_i} \frac{\beta_i N^{\alpha_i}}{(\alpha_i + n + 1)\Gamma(\alpha_i + 1)}$$

# $\pi N$ charge exchange

As a first application we consider  $k [\sigma_{\tau} (\pi^{-} p) - \sigma_{\tau} (\pi^{+} p) ]$  which should be dominated by the  $\rho$  Regge pole. There exist very good data for low energies, and a smooth fit by the Regge pole can be observed from 4 GeV onwards. The sum rule holds within experimental accuracy.

Igi and Matsuda, PRL 1967.

Horn and Schmid, 1967.

Logunov et al PL 1967

Dolen Horn Schmid PRL 1967 PR 1968

This figure compares  $\Delta\sigma_{\tau}$  (1) with the Regge fit (4). It shows also that sum of resonances (2) approximates quite well  $\Delta\sigma_{\tau}$  at low energies.

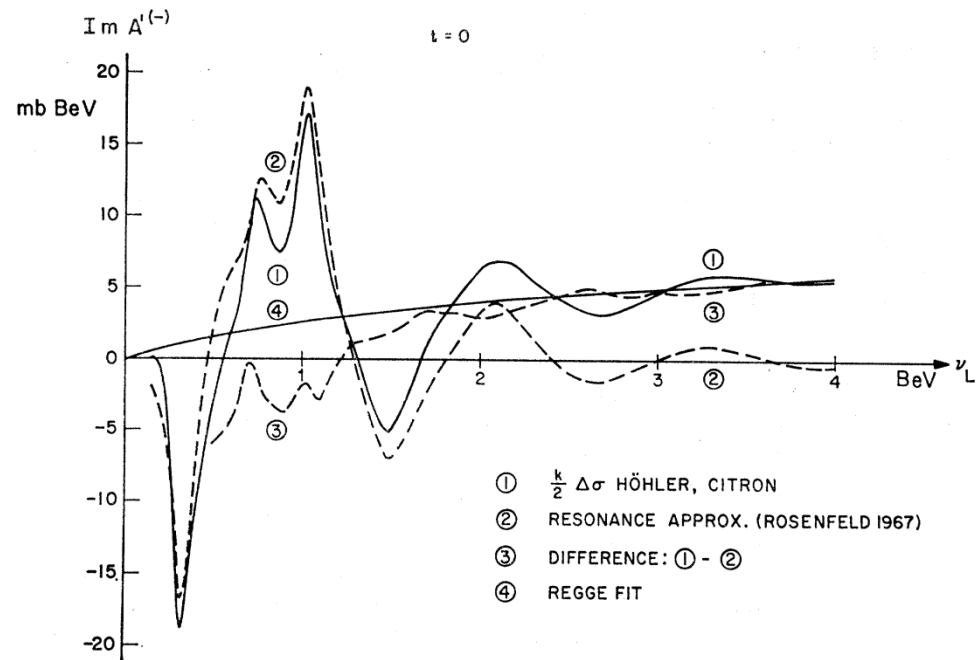

# $\pi N$ charge exchange near forward scattering

Formalism (Singh PR 63, pion mass=1, nucleon mass=m):

$$d\sigma/d\Omega = |f_1 + f_2|^2 + (t/k^2) \operatorname{Re} f_1^* f_2,$$

$$f_i = f_i^{(+)} \pm f_i^{(-)} \quad \text{for } \pi^\mp p \rightarrow \pi^\mp p,$$

$$\sigma^{\text{total}} = \frac{4\pi W}{m(\omega^2 - 1)^{\frac{1}{2}}} \operatorname{Im}(f_1 + f_2)_{t=0},$$

$$f_i = -\sqrt{2} f_i^{(-)} \quad \text{for } \pi^- p \rightarrow \pi^0 n.$$

$\omega = (s - m^2 - 1)/(2m)$  = the lab energy of the pion.       $W$  is total energy in center of mass.

Using the amplitudes  $A$  and  $B$  of Chew et al, Singh introduced

$$A' = A + \frac{\omega + t/(4m)}{1 - t/(4m^2)} B,$$

$$\frac{d\sigma}{d\Omega} = \left( \frac{m}{4\pi W} \right)^2 \left[ \left( 1 - \frac{t}{4m^2} \right) |A'|^2 \right.$$

$$\left. + \frac{t}{4m^2} \left( s - \frac{(m + \omega)^2}{1 - t/(4m^2)} \right) |B|^2 \right],$$

In terms of which one obtains

and

$$\sigma^{\text{total}} = \frac{1}{(\omega^2 - 1)^{\frac{1}{2}}} \operatorname{Im} A'(s; t=0).$$

# $\pi N$ charge exchange forward scattering Regge amplitudes

$$a_{\text{Asym}}(\nu, t) = -\nu \sum_i \frac{\gamma_i(t)}{\sin(\pi\theta_i/2)} \exp\left[-i\frac{\pi}{2}\theta_i\right] (\nu^2 - \nu_0^2)^{\theta_i/2}$$

$$\theta_i = \alpha_i(t) \quad \text{for } \nu A'^{(+)}$$

$$\theta_i = \alpha_i(t) - 2 \quad \text{for } B^{(+)}$$

$$\theta_i = \alpha_i(t) - 1 \quad \text{for } A'^{(-)} \text{ and } \nu B^{(-)}$$

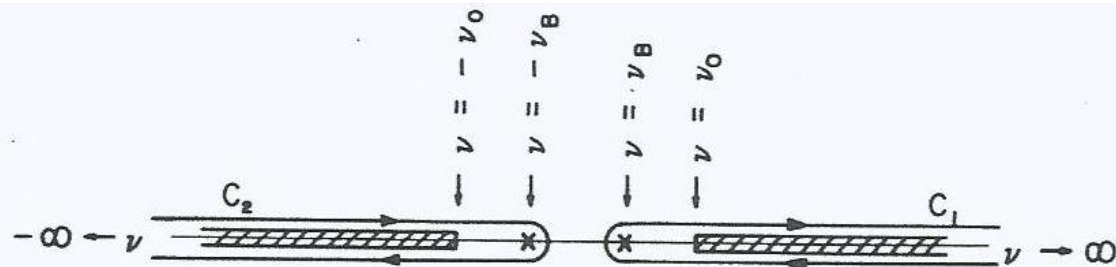
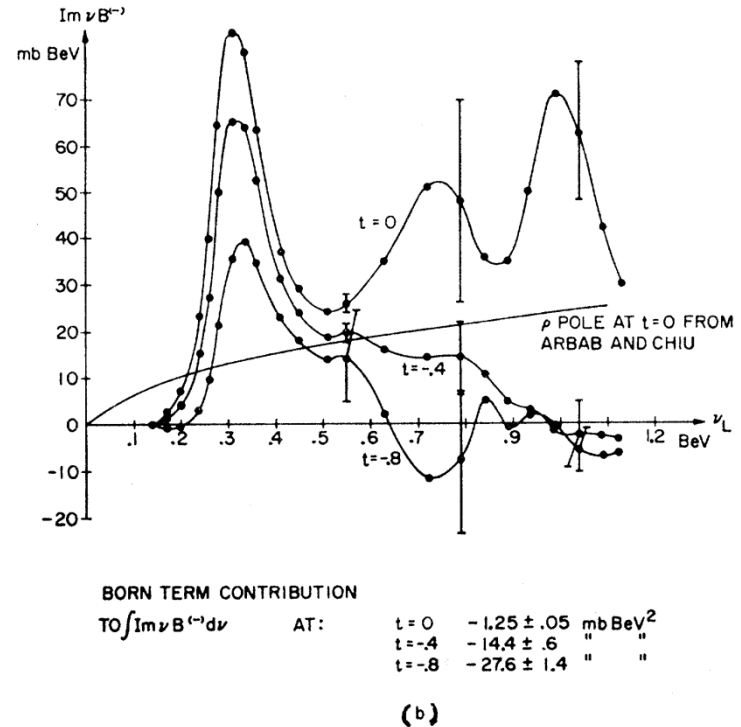
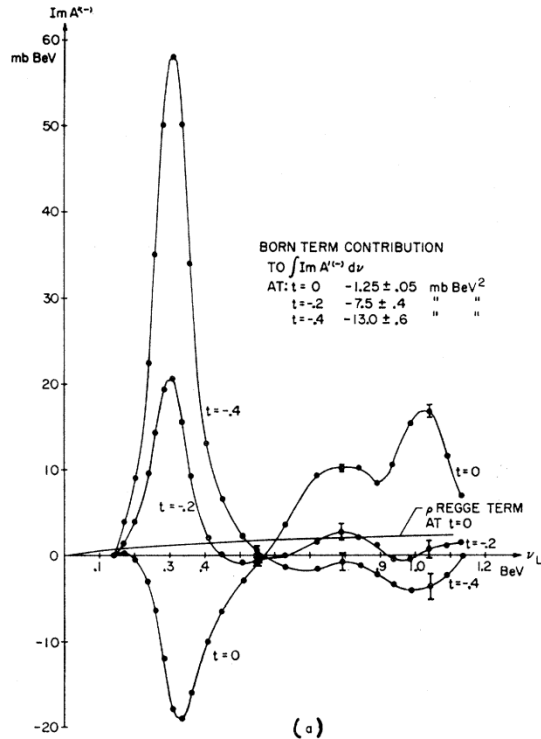

Figure 10.2. Contour  $C = C_1 + C_2$  in the complex  $\nu$  plane used in deriving finite energy sum rules for  $\pi N$  elastic amplitudes.

# $\pi N$ charge exchange forward scattering



t-dependence of the two scattering amplitudes, as determined from phase-shift analysis.

Predictions:

1. At  $t=0$   $B > A'$ , because different resonances cancel out in  $A'$  and sum up in  $B$ . This explains the high forward peak in  $\pi N$  charge exchange
2.  $B$  develops a zero at  $t=-.5$  and  $A'$  develops a zero at  $t=-0.15$  GeV<sup>2</sup>.

# Consistent behavior of Resonances with Regge poles

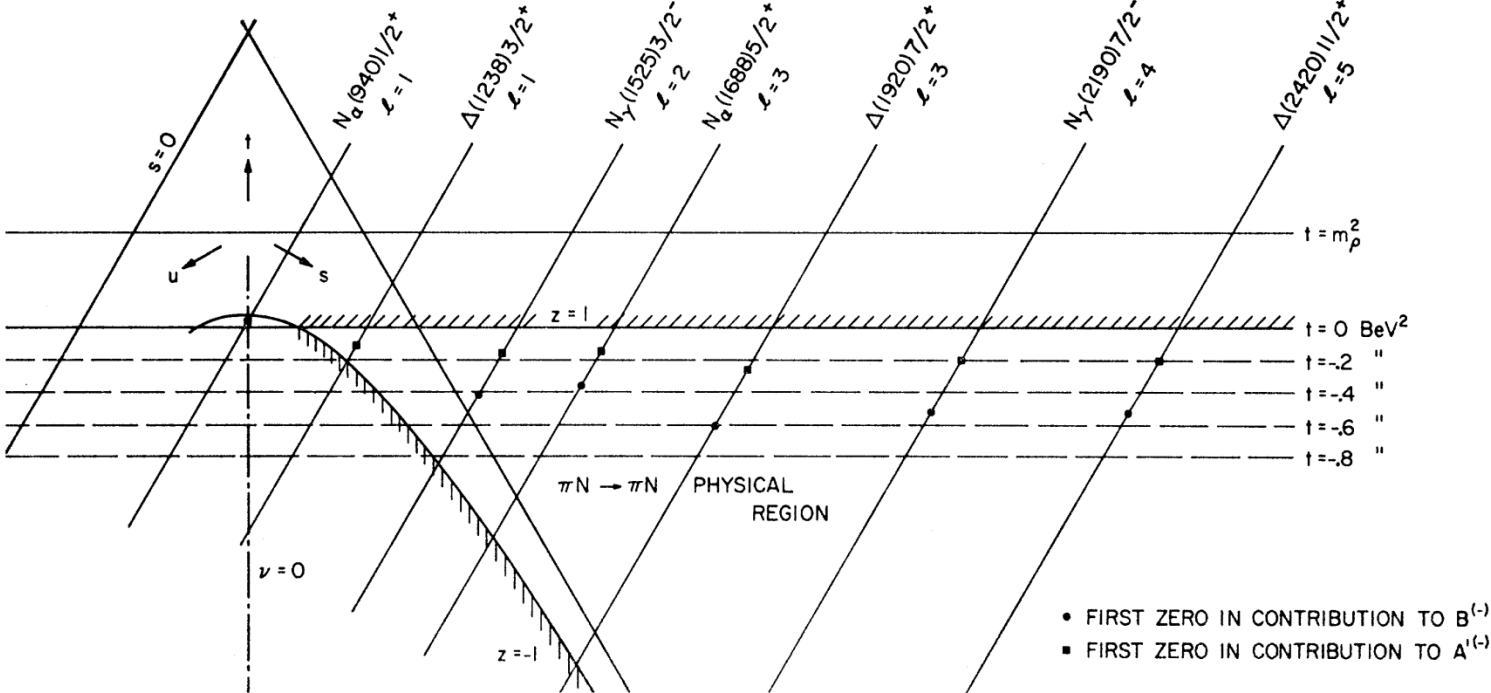
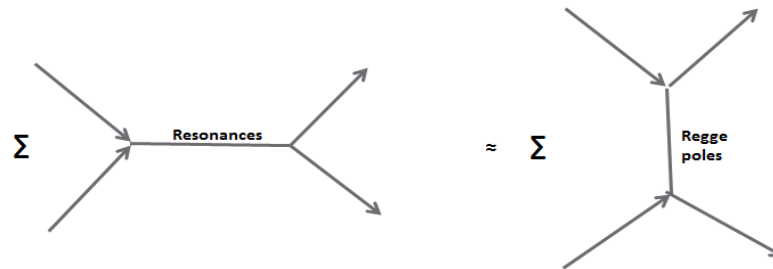

FIG. 5. First zeros of the prominent resonances on the Mandelstam plot for the  $\pi N$  problem.

# Realization of the Bootstrap idea

The  $\pi N$  charge-exchange example, has become a realization of the Chew-Frautschi Bootstrap idea: with the LHS being dominated by resonances (in the s-channel) and the RHS by Regge poles (in the t-channel), this may be viewed as part of a self-consistent relationship of hadronic states



Chew (1968) has called it “Horn-Schmid duality”.

In addition to becoming the realization of a new principle, note that this approach went against the then common trend to sum both types of contributions, resonances and Regge exchanges, to the scattering amplitude. This practice has followed the common experience from the use of Feynman diagrams, which the FESR have shown to involve double-counting.



# Duality and the Pomeron

Could it be that Pomeron is due to non-resonant scattering, while all other Regge trajectories are dual to resonances?

Here is what Chew has said in 1968:

The bootstrap aspect of Horn-Schmid duality throws new light on the peculiar dynamical role of the Pomeron trajectory, the Regge singularity which dominates the very high energy behavior of all elastic and some inelastic amplitudes, even those which lack prominent low-energy resonances. Schmid<sup>6</sup> has emphasized the consistency of the latter circumstance with the absence of low-mass resonances on the Pomeron trajectory itself, as well as with the small slope thereof. Precisely these features allow the Pomeron trajectory to stand apart from the interplay of first-order bootstrap constraints. Harari<sup>9</sup> has suggested associating the Pomeron contribution with “background” at low energy, whether or not prominent resonances there appear. Such an association might explain why total cross sections systematically approach their high-energy limits from above.

# Is duality perfect?

Is the single Regge pole a good approximation?

DHS PR 68: Not really. But a sum of Regge poles may be OK.

In an effective one-pole model, we predict the  $\rho$  mass and a trajectory  $\alpha_{\text{eff}}$  which is 0.1 to 0.2 lower than the one measured at high energies. (5) Using high-energy fits as an additional input, we find some evidence for a second  $\rho$  trajectory, 0.4 lower than the  $\rho$ . This may be the manifestation of a cut. (6) Using the parameters of the additional  $\rho$  pole, we predict a polarization of the right sign and order of magnitude.

Does duality hold for all scattering amplitudes?

Although various scattering amplitudes seem to be dominated by resonances, there exist nonetheless contributions which look like non-resonant background.

Nonetheless, this did not discourage theoreticians from searching for perfect examples..

# A mathematical example

demonstrating how a function dominated by an infinite series of poles can nonetheless have an asymptotic description analogous to a Regge pole.

$$F(\nu) = \psi(\nu) - \psi(1-\nu) = -\pi \cot(\pi\nu)$$

$$\psi(\nu) = \frac{d}{d\nu} \ln \Gamma(\nu) \qquad -F = \frac{1}{\nu} + 2\nu \sum_{k=1}^{\infty} \frac{1}{\nu^2 - k^2}$$

F has poles at all positive and negative integers, yet Im F has an asymptotic expansion consisting of one term,  $i\pi$ , like a single Regge pole with power 0.

For  $\nu = re^{i\theta}$  use the ray  $\theta = \text{const}$  and expand

$$\text{Im} F = \frac{\sin\theta}{r} + 2 \sum_{k=1}^{\infty} \frac{(r+k^2/r)\sin\theta}{(r+k^2/r)^2 \sin^2\theta + (r-k^2/r)^2 \cos^2\theta}$$

We expect this expression to be dominated by “resonances” at low energies and a single pole at high energies.

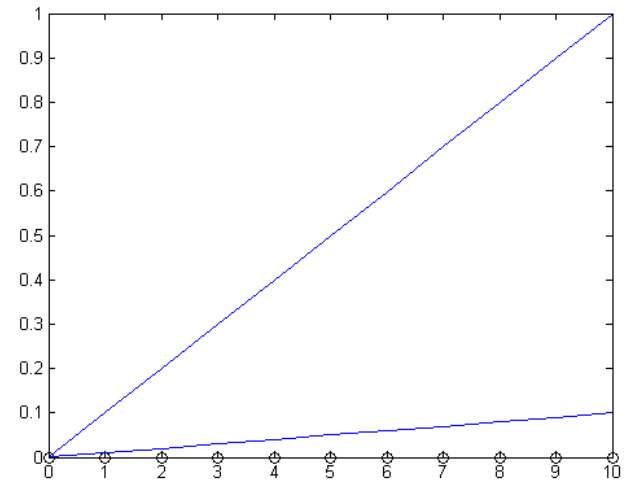

Two rays in the complex  $\nu$  plane

$$\text{Im}F = \frac{\sin\theta}{r} + 2 \sum_{k=1}^{\infty} \frac{(r + k^2/r)\sin\theta}{(r + k^2/r)^2 \sin^2\theta + (r - k^2/r)^2 \cos^2\theta}$$

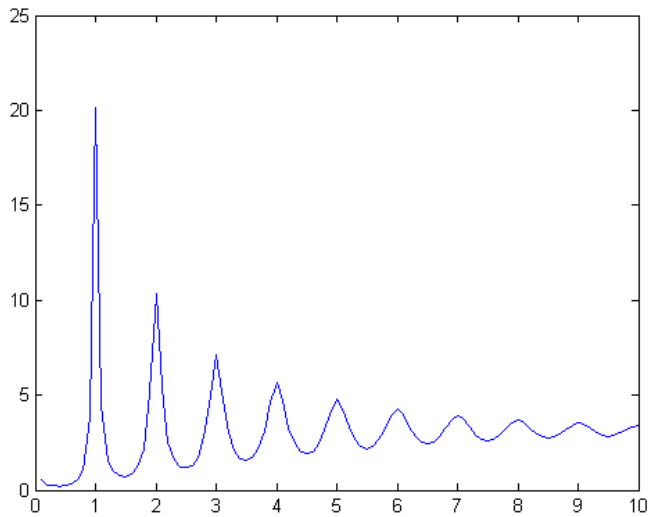

ImF as function of r for  $\theta=0.05$

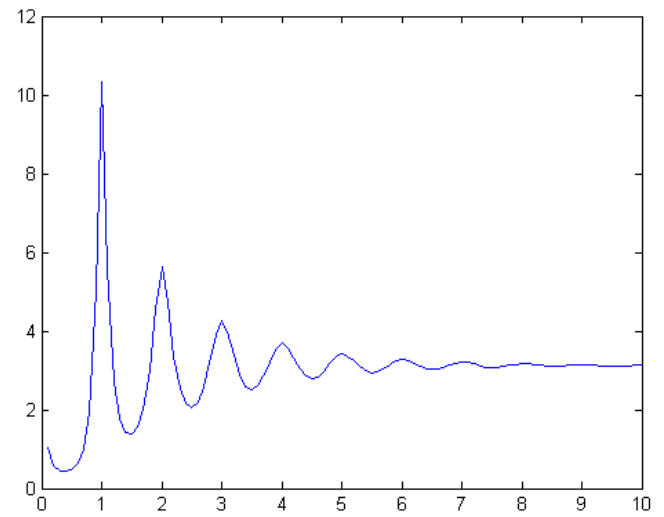

ImF as function of r for  $\theta=0.1$

# Interlude: the Gamma function

$$\Gamma(z) = \int_0^{\infty} t^{z-1} e^{-t} dt \quad (\Re z > 0)$$

**Integer Values**

$$\Gamma(n+1) = 1 \cdot 2 \cdot 3 \dots (n-1)n = n!$$

$\Gamma(z)$  is analytic with poles at 0 and negative integers

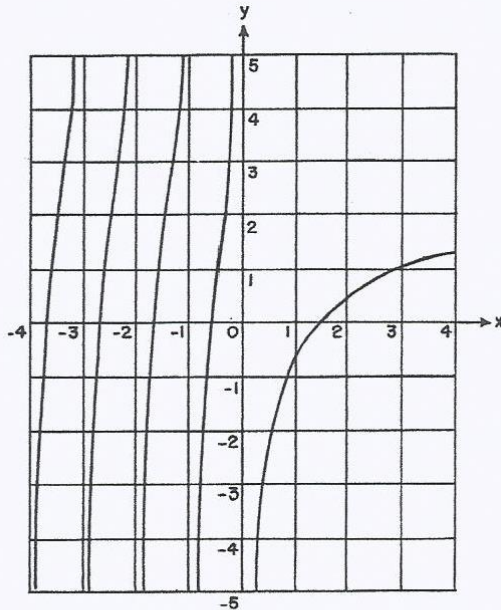

FIGURE 6.2. Psi function.

$$y = \psi(x) = d \ln \Gamma(x) / dx$$

Asymptotic expansion  

$$\Gamma(z) \rightarrow e^{-z} z^{z-1/2} (2\pi)^{1/2}$$

$$B(z, w) = \frac{\Gamma(z)\Gamma(w)}{\Gamma(z+w)} = B(w, z)$$

$$\psi(z) = d[\ln \Gamma(z)] / dz = \Gamma'(z) / \Gamma(z)$$

$$\psi(z+1) = \psi(z) + \frac{1}{z}$$

From Abramowicz and Stegun: Handbook of Mathematical Functions. NBS 1964

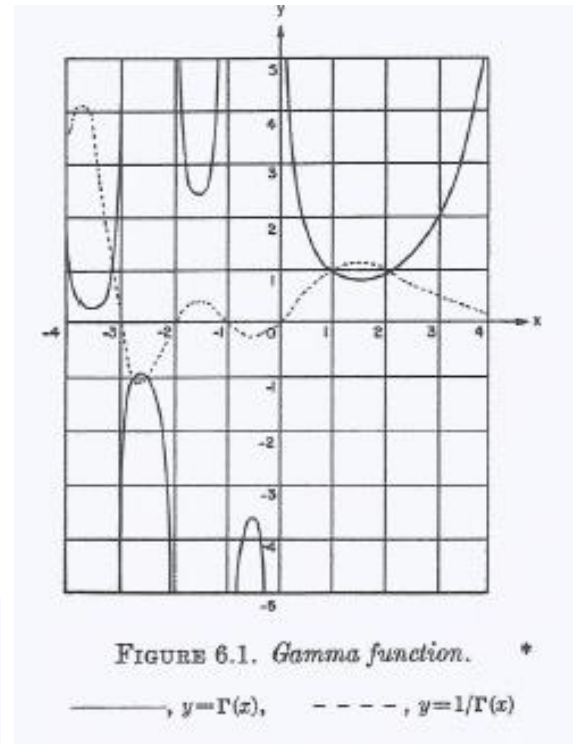

FIGURE 6.1. Gamma function. \*

—,  $y = \Gamma(x)$ , - - - - ,  $y = 1/\Gamma(x)$

# The Veneziano Model

Consider the process  $\pi\pi \rightarrow \pi\omega$  which has no elastic channel, and all crossings from  $s$  to  $t$  and  $u$  may be viewed as dominated by resonances. The T-matrix can be written as

$$T = \varepsilon_{\mu\nu\rho\sigma} e_\mu P_{1\nu} P_{2\rho} P_{3\sigma} \cdot A(s, t, u)$$

expressed in terms of the three pion momenta and the polarization vector of  $\omega$ . In the large  $s$  limit  $A$  can be assumed to be represented by a Regge pole

$$A(s, t, u) \underset{s \rightarrow \infty}{\simeq} \frac{\bar{\beta}}{\pi} \Gamma(1 - \alpha(t)) (-\alpha(s))^{\alpha(t)-1} + (s \leftrightarrow u)$$

which Veneziano has generalized into a fully Mandelstam symmetric expression using

$$A(s, t, u) = \frac{\bar{\beta}}{\pi} [B(1 - \alpha(t), 1 - \alpha(s)) + B(1 - \alpha(t), 1 - \alpha(u)) + B(1 - \alpha(s), 1 - \alpha(u))] \quad B(x, y) = \frac{\Gamma(x)\Gamma(y)}{\Gamma(x+y)}$$

the Euler beta function. If  $\alpha(t)$  is real, then  $\text{Im}A$  becomes a series of delta-functions. If it is complex and linear it will have the expected physical behavior

An explicit expansion provides the expression

$$A = \frac{\beta(t)}{\sin \pi \alpha(t)} \left[ -\frac{\sin \pi(\alpha(s) + \alpha(t))}{\sin \pi \alpha(s)} \frac{\Gamma(\alpha(s) + \alpha(t) - 1)}{\Gamma(\alpha(s))} + \frac{\Gamma(1 - \alpha(u))}{\Gamma(2 - \alpha(u) - \alpha(t))} \right]$$

which has the real part

$$\beta(t) \frac{1 - \cos \pi \alpha(t)}{\sin \pi \alpha(t)} [\alpha(s)]^{\alpha(t)-1}, \quad \beta(t) = \bar{\beta} \Gamma(\alpha(t)),$$

and imaginary part

$$A \underset{s \rightarrow \infty}{\sim} -\beta(t) \operatorname{ctg} \alpha(s) [\alpha(s)]^{\alpha(t)-1}$$

(remember that  $\cot(\pi s) \rightarrow -i$ )

By imposing further conditions to eliminate unwanted poles, Veneziano reexpressed  $A$  in a very symmetric form:

$$A = \frac{\bar{\beta}}{\pi^2} \Gamma(1 - \alpha(s)) \Gamma(1 - \alpha(t)) \Gamma(1 - \alpha(u)) [\sin \pi \alpha(s) + \sin \pi \alpha(t) + \sin \pi \alpha(u)].$$

This leads to an infinite family of equally spaced Regge poles.

## Duality Diagrams

A merger of the duality principle and the quark model came about through the duality diagrams which have been proposed by Harari [1969] and by Rosner [1969]. The diagrams display scattering amplitudes in terms of two- or three- quark components, as befitting mesons and baryons, but their s- and t-structure is that of a dual amplitude.

Examples of predictions:

(1) The following processes cannot be represented by legal diagrams and are among those predicted to have purely real amplitudes at small  $t$  values:  $K^+n \rightarrow K^0p, K\Delta, K^*N, K^*\Delta$ , and  $K^-p \rightarrow \pi^-\Sigma^+, \pi^0\Sigma^0, \pi^0\Lambda, \rho^0\Lambda, \omega\Lambda$ . The general rule is that all processes of the form  $K^-B \rightarrow \pi^-B', \pi^+B \rightarrow K^0B', K^+B \rightarrow K^0B',$  and  $\bar{K}B \rightarrow M^0B'$  are predicted to have vanishing imaginary parts, where  $B, B'$  are any nonexotic baryons and  $M^0$  is any  $Q = Y = 0$  meson which does not contain a  $\lambda\bar{\lambda}$  component

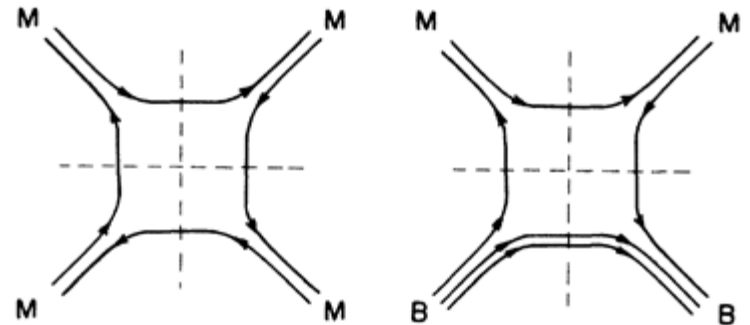

$$\begin{aligned} \text{Im}(\pi^-p \rightarrow \rho^0n) &= -\text{Im}(\pi^-p \rightarrow \omega n); & \text{Im}(\pi^+n \rightarrow \rho^0p) &= +\text{Im}(\pi^+n \rightarrow \omega p); \\ \text{Im}(\pi^+p \rightarrow \omega\Delta^{++}) &= +\text{Im}(\pi^+p \rightarrow \rho^0\Delta^{++}); & \text{Im}(\pi^-p \rightarrow f^0n) &= -\text{Im}(\pi^-p \rightarrow A_2^0n); \\ \text{Im}(\rho^0p \rightarrow K^+\Lambda) &= +\text{Im}(\omega p \rightarrow K^+\Lambda); & \text{Im}(\rho^0p \rightarrow \pi^-\Delta^{++}) &= -\text{Im}(\omega p \rightarrow \pi^-\Delta^{++}), \text{ etc.} \end{aligned}$$



# Duality Diagrams – extension to multi-particle production

## Example of a multiparticle prediction

(5) There is no legal diagram for the process  $\pi^- p \rightarrow K^- K^+ n$  if we insist that the outgoing neutron is “tied” to the incoming proton. On the other hand,  $\pi^- p \rightarrow K^0 K^0 n$  is perfectly legal. One way of understanding this peculiar prediction is to consider the  $K\bar{K}$  pair as coming from intermediate  $Q = Y = 0$  mesons. The initial  $\pi^-$  is allowed by our diagrams to produce only coherent mixtures of  $I = 0$  and  $I = 1$  mesons. These mixtures are forbidden to decay into  $K^- K^0$  while the  $K^0 \bar{K}^0$  mode is allowed.

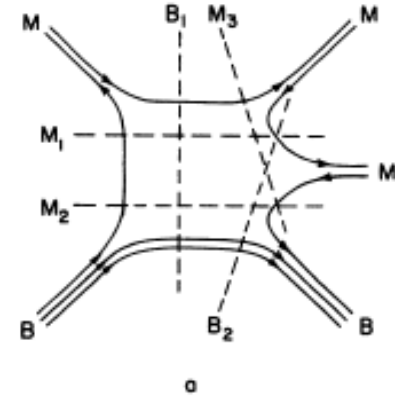

## Importance of quarks vs flavor SU(3)

The assumptions involved in drawing are stronger than the requirement that the exotic SU(3) amplitudes vanish in all channels.<sup>4</sup> Our extra assumption can be most easily stated in the SU(3)-invariance limit (although it is not necessary to take this limit here). What we assume in addition is that  $4q + \bar{q}$  or  $2q + 2\bar{q}$  intermediate states are illegal even if they happen to belong to a singlet or an octet. Another way of stating the same assumption is to note that our annihilated  $q\bar{q}$  pairs in all channels must be in SU(3) singlets and not in octets. This assumption is certainly reasonable if real quarks exist, but even if the quarks are only mathematical entities representing some algebraic structure, it is conceivable that they obey our requirements.

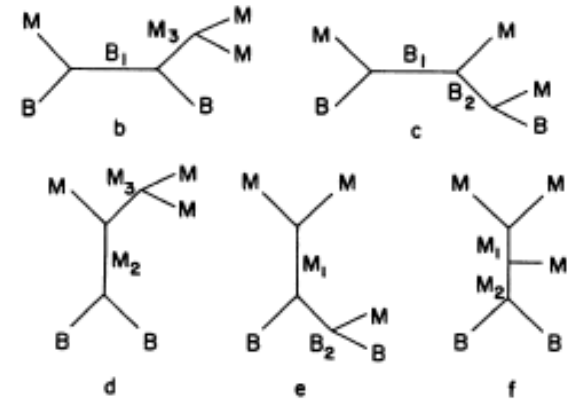

## multi-particle production

The light quarks, u d and s, form the basis of flavor-SU(3). This symmetry would seemingly predict similarity between kaons and pions. Hadron production experiments demonstrate extensive multi-pion production with no equivalent multi-kaon production. The low-mass pion (Nambu-Goldstone boson of chiral symmetry breaking) is therefore quite exceptional among all mesons.

Average charge multiplicities in pp processes:  
Note dominance of pions over kaons.  
Thus, whereas total, elastic and inclusive cross-sections exhibit flavor similarity, exclusive multi-particle production is different  
It is mostly multi-pion production.

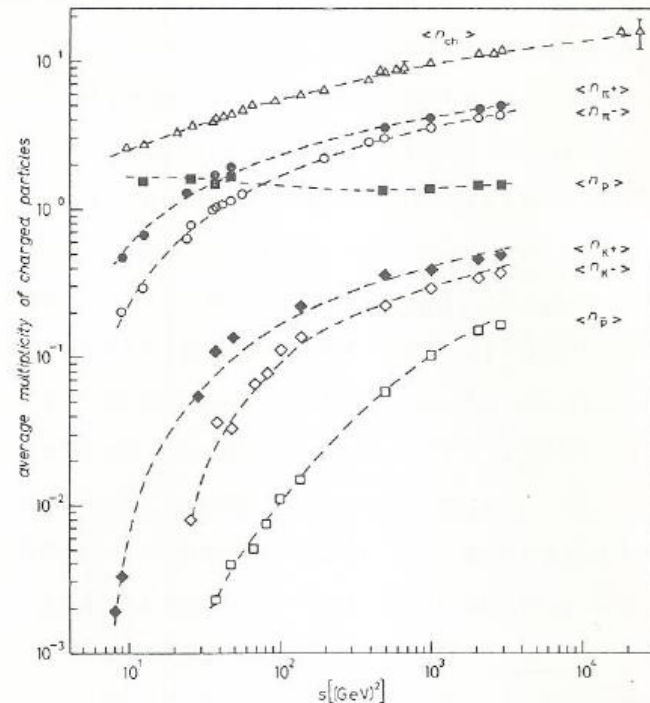

# References

- V.D.Barger and D.B.Cline. Phenomenological Theories of High Energy Scattering. W.A.Benjamin, Inc. 1969.
- R.N.Cahn and G. Goldhaber. The Experimental Foundations of Particle Physics. Cambridge University Press, 1989.
- G.F.Chew, M.L.Golberger, F.E.Low and Y. Nambu. Application of Dispersion Relations to Low-Energy Meson-Nucleon Scattering. Phys. Rev. 106, 1337 (1957).
- G.F.Chew and S.C.Frautschi. Principle of Equivalence for all Strongly Interacting Particles within the S-Matrix Framework. Phys. Rev. Lett. 7, 394 (1961). Regge trajectories and the principle of maximum strength for the strong interactions. Phys. Rev. Lett. 8, 41 (1962).
- G.F.Chew. Horn-Schmid Duality. Comments on Nuclear and Particle Physics 74-76 (1968).
- R. Dolen, D. Horn and C. Schmid. Prediction of Regge-parameters of rho poles from low-energy pi-N scattering data. Phys. Rev. Lett. 19, 402-407 (1967). Finite-Energy Sum Rules and Their Application to pi-N Charge Exchange. Phys. Rev. 166, 1768-1781 (1968).
- H. Harari. Duality Diagrams. Phys. Rev. Lett. 22, 562 (1969).
- D. Horn and C. Schmid. Finite Energy Sum Rules. Unpublished report CALT-68-127, April 1967.
- D. Horn and F. Zachariasen. Hadron Physics at Very High Energies. W. A. Benjamin Inc., 1973.
- K. Igi and S. Matsuda. New sum rules and singularities in the complex J plane. Phys. Rev. Lett. 18, 625 (1967).
- A. Logunov, L.D. Soloviev, and A.N. Tavkhelidze, Dispersion sum rules and high energy scattering. Phys. Letters 24B, 181 (1967).
- S. Mandelstam. Determination of the Pion-Nucleon Scattering Amplitude from Dispersion Relations and Unitarity. Physical Review 112 (4): 1344 (1958).
- V. Singh. Regge Poles in  $\pi N$  Scattering and in  $\pi \pi \rightarrow N\bar{N}$ . Phys. Rev. 119, 1889 (1963).
- T. Regge. Introduction to complex orbital momenta. Nuovo Cim. 14, 951 (1959) Bound states, shadow states and Mandelstam representation. Nuovo Cim. 18, 947 (1960).
- J. L. Rosner. Graphical Form of Duality. Phys. Rev. Lett. 22, 689 (1969).
- G. Veneziano. Construction of a crossing-symmetric, Regge-behaved amplitude for linearly rising trajectories. Nuovo Cimento A 57: 190 (1968).