

Complex analysis in a nut shell

1: Introduction

Complex algebra and geometric interpretation

Elementary functions, domains, maps

Differentiation, Cauchy relations, harmonic functions

2: Complex integrals

Cauchy theorem implications and applications

3: Analytic continuation

Multivalued functions

Branch points, Riemann sheets

Conditions for singularities of integral transforms

History and motivation

Positive integers: $5=3+2$ ok but $3-5$ is unaccounted for

Were sufficient for about 2000y, Geeks did not use negatives and even after 0 was introduced by Brahmagupta ~628 they were not used until development of axiomatic algebra

Fractional numbers: $3/2$ ok but $x^2=2$ unaccounted for

Positive integers and fractions were the pillars of Greek's natural number system, who assumed they are continuously distributed. In 1872 Richard Dedekind showed that they "leave holes" for irrational numbers.

Imaginary numbers: $x^2 = -1$

Introduced by Girolamo Cardano in 1545, Leonhard Euler introduced "i" in eighteenth century, in 1799 Friedrich Gauss introduced 2dim geometric interpretation, which was abandoned till reintroduced in 1806 by Robert Argand. Complex calculus was pioneered by Augustin Cauchy in nineteenth century.

Physical quantities are Real.

However, they often come in pairs, e.g. amplitude and phase that have simple representation in terms of complex numbers. In such cases complex numbers simplify how physical laws are expressed and manipulated.

Complex algebra

$$z_1 = a + b i, z_2 = c + d i$$

$$z_1 + z_2 = (a + c) + (b + d) i$$

$$z_1 * z_2 = (a c - b d) + (a d + b c) i$$

$$z_1 = |z_1| \cos \phi_1 + |z_1| i \sin \phi_1$$

complex numbers
= field (+, . and
distribution law)

$$z(u + w) = zu + zw$$

$$|z_1| = \sqrt{a^2 + b^2}$$

$$\phi_1 = \arctan \frac{b}{a}$$

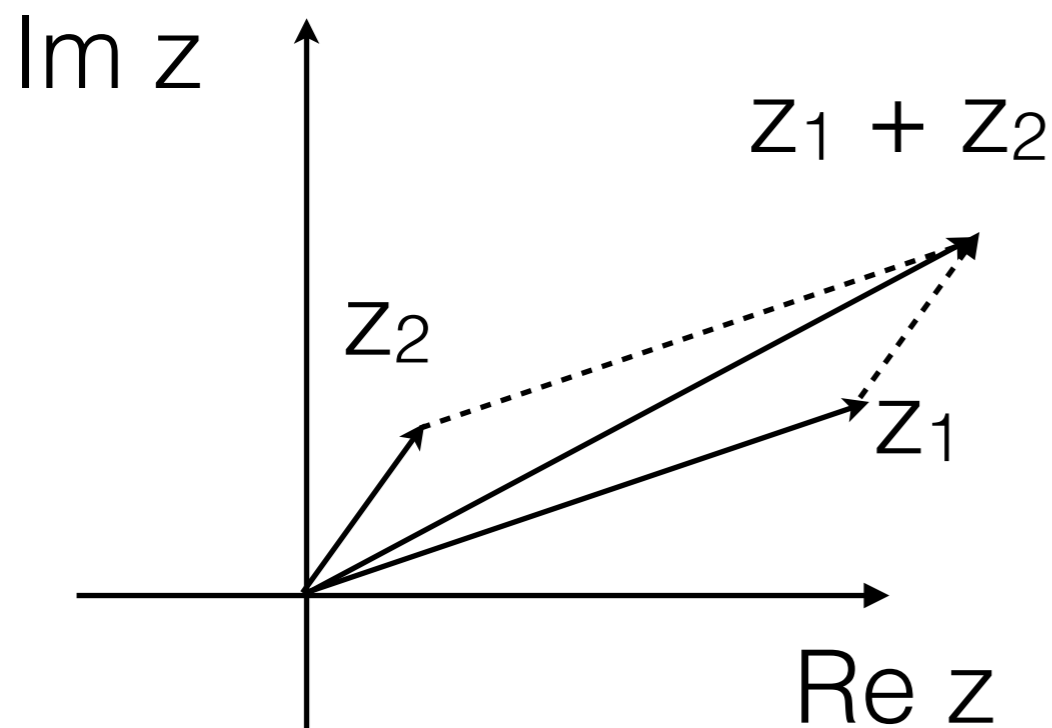

De Moivre's formula

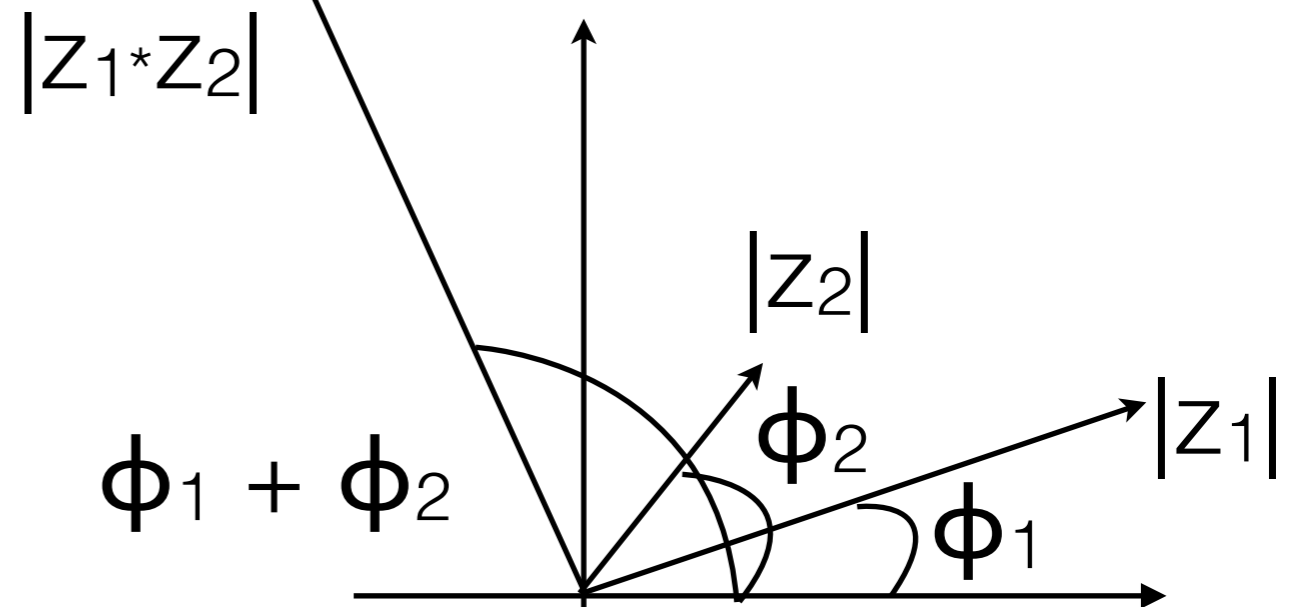

$$z^n = |z|^n (\cos n\phi + i \sin n\phi)$$

Complex functions: definitions

Complex functions

$$z = a + bi \rightarrow f(z) = \operatorname{Re}f(z) + i\operatorname{Im}f(z)$$

Elementary functions: you can also think of them as maps of one complex plane (z) to another ($f(z)$): $z \rightarrow f(z)$

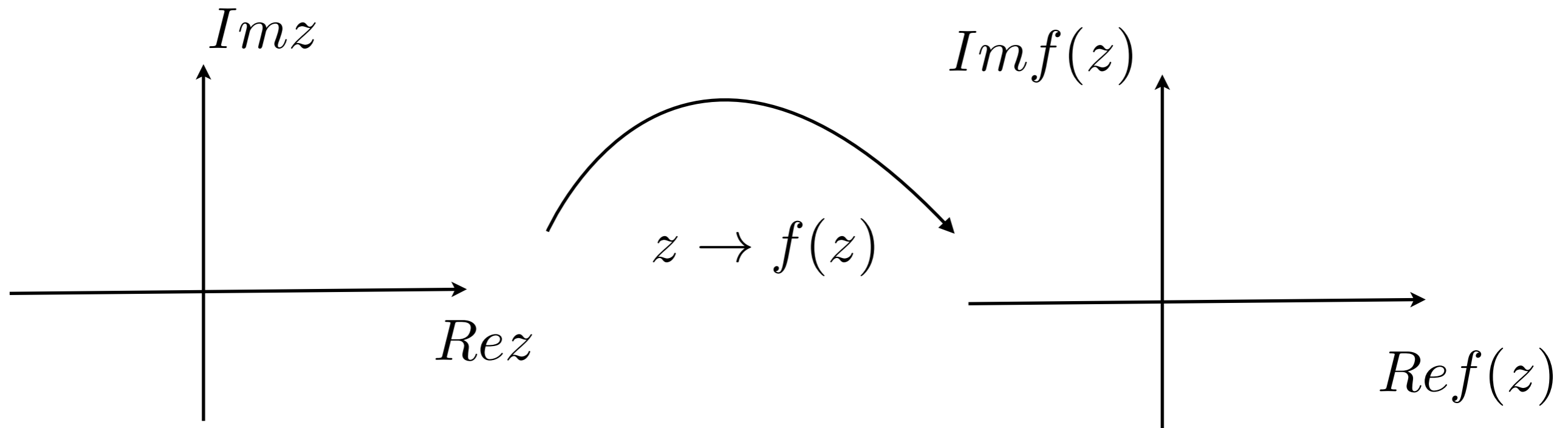

To define a function we can use the algebraic relations e.g

$$f(z) = \sqrt{z} \quad \text{is such that} \quad z = f(z) \times f(z)$$

Examples

find solutions of $z^8 = 1$

simplify $\frac{1+i}{2-i}, \sqrt{1+\sqrt{i}}$

show that maximum absolute value of z^2+1 on a unit disk $|z|\leq 1$ is 2

show that

$$1 + \cos \phi + \cos 2\phi + \cdots + \cos n\phi = \frac{1}{2} + \frac{\sin(n + \frac{1}{2})\phi}{2 \sin \frac{\phi}{2}}$$

solve $\frac{d^2 x(t)}{dt^2} + \omega^2 x^2(t) = 0$

Complex functions (and complex calculus) : Continuity imposes very strong conditions of functions (much stronger than in the case of real variables)

“Smooth” (holomorphic, analytic) functions are “boring” all “action” is in the singularities.

Singularities determine functions “far away” from location of the singularity (e.g. charge determines potentials)

Physical observables are functions of real parameters, however physics law can be generalized to complex domains and become “smooth” but any “constraint” results in singularities.

Complex functions: branches

$\exp(z)$ is periodic!

(exp of complex argument has the same algebraic properties as exp of real arg., e.g. $\exp(z_1 z_2) = \exp(z_1) \exp(z_2)$)

$$e^{i\phi} = \left[1 - \frac{\phi^2}{2} + \dots\right] + i\left[\phi - \frac{\phi^3}{3!} + \dots\right] = \cos \phi + i \sin \phi$$

$$z \rightarrow e^z = e^{\operatorname{Re}z + i\operatorname{Im}z} = e^{\operatorname{Re}z} (\cos \operatorname{Im}z + i \sin \operatorname{Im}z)$$

$$e^{z+2\pi i} = e^z$$

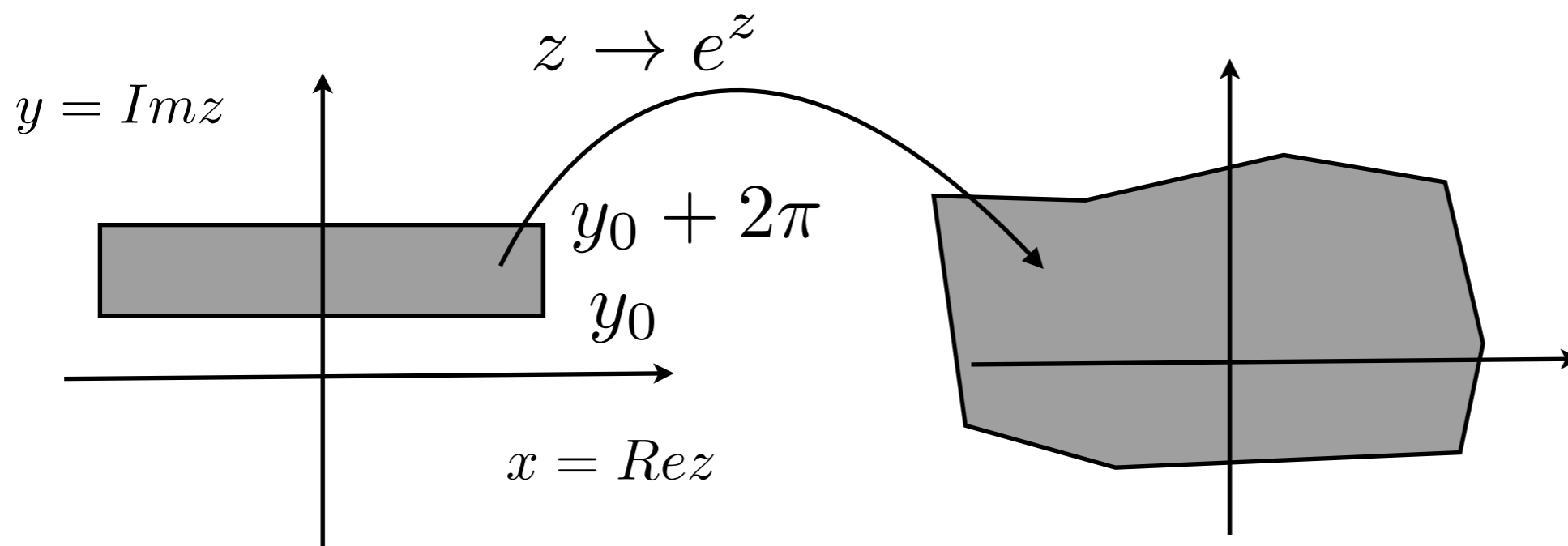

one needs to be careful when defining its inverse i.e. logarithm:
the z -plane can be mapped back in many different ways

similar issue with the \sqrt{z}

$$z = |z|e^{i\phi}$$

$$\sqrt{z} \equiv \sqrt{|z|}e^{i\frac{\phi}{2}}$$

$$\sqrt{z}\sqrt{z} = \sqrt{|z|}e^{i\frac{\phi}{2}} \sqrt{|z|}e^{i\frac{\phi}{2}} = |z|e^{i\phi}$$

using $\phi = [-\pi, \pi)$

or $\phi = [0, 2\pi)$

gives different results for \sqrt{z}

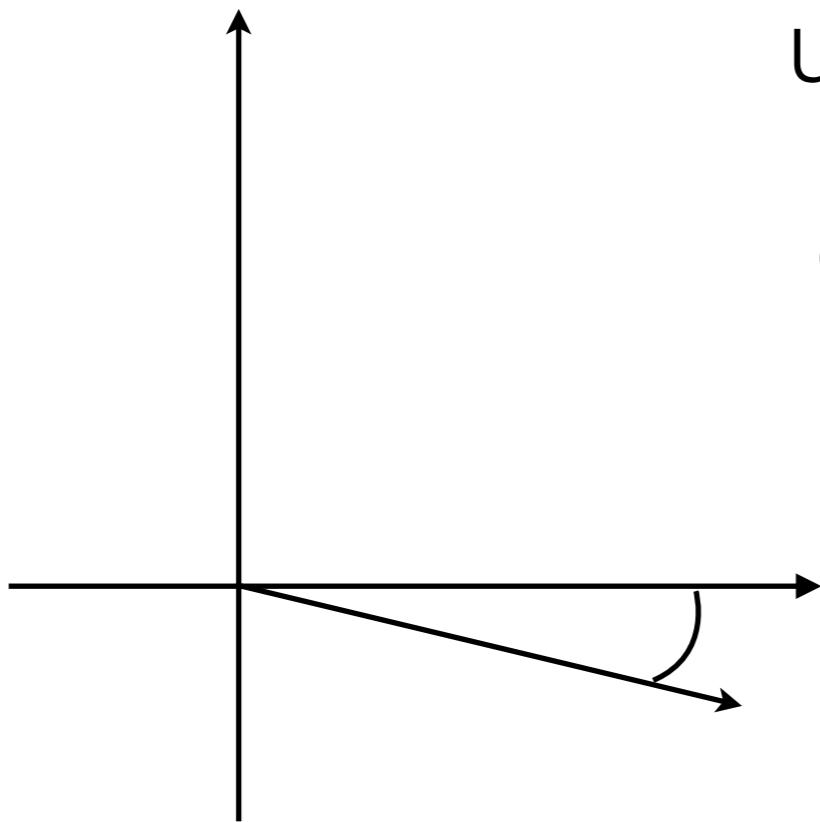

$\log: \mathbb{C} - \{0\} \rightarrow \mathbb{C}$ with range defined $y_0 \leq \text{Im } \log z < y_0$

$+2\pi: \log z = \log|z| + i \arg z$ (many "log"-functions depending on the choice of y_0)

Principal branch: $y_0 = -\pi$ so that $-\pi \leq \arg z < \pi$

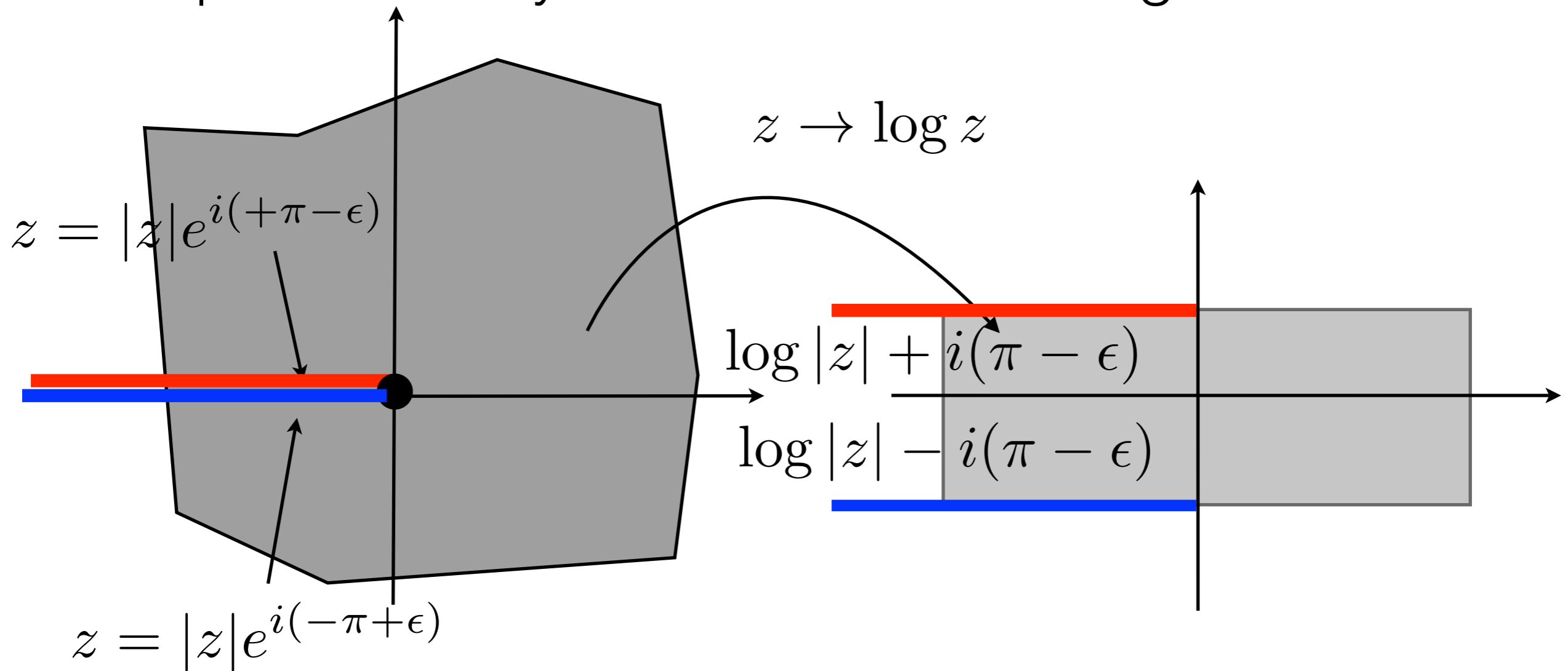

\log is discontinuous on its *branch line* and $z=0$ is the *branch point* ●

Case A: $-\pi \leq \text{Im} \log z < \pi$

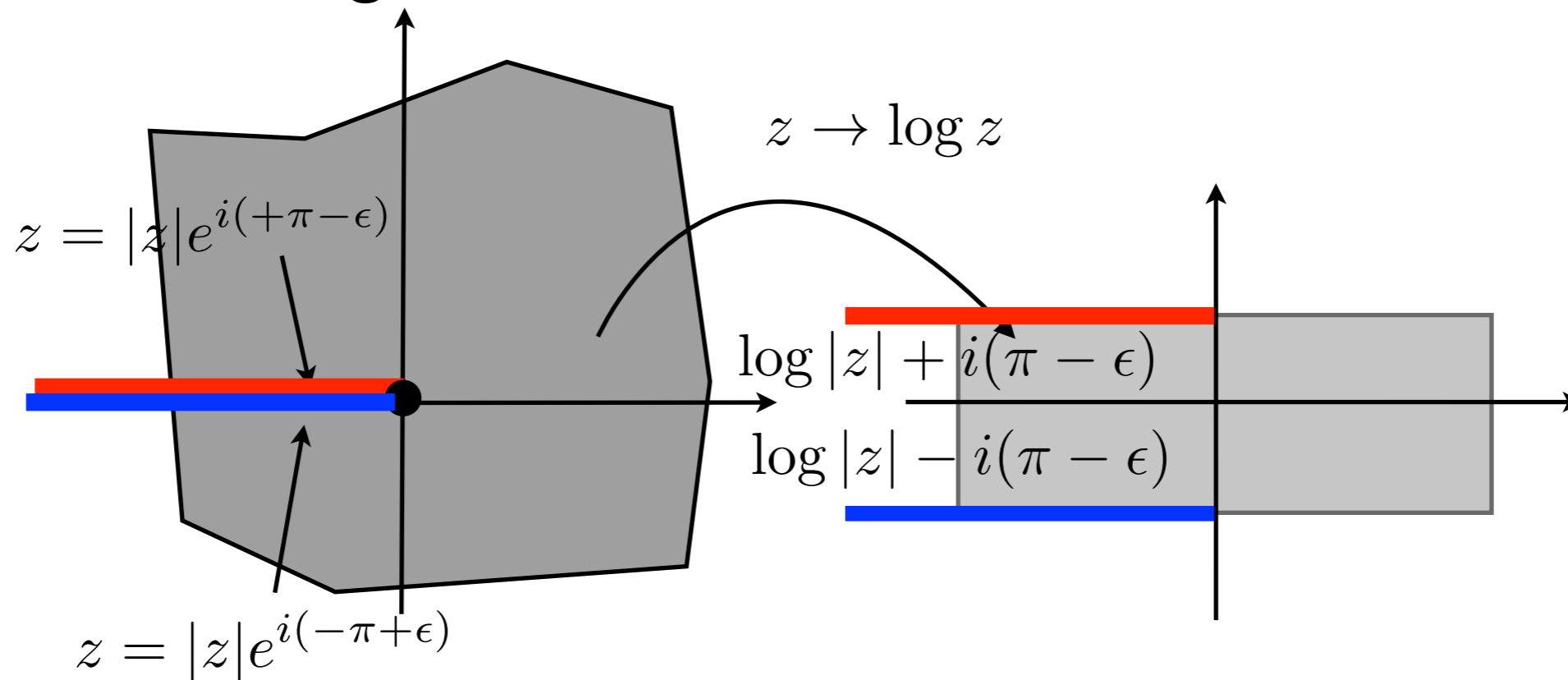

Case B: $0 \leq \text{Im} \log z < 2\pi$

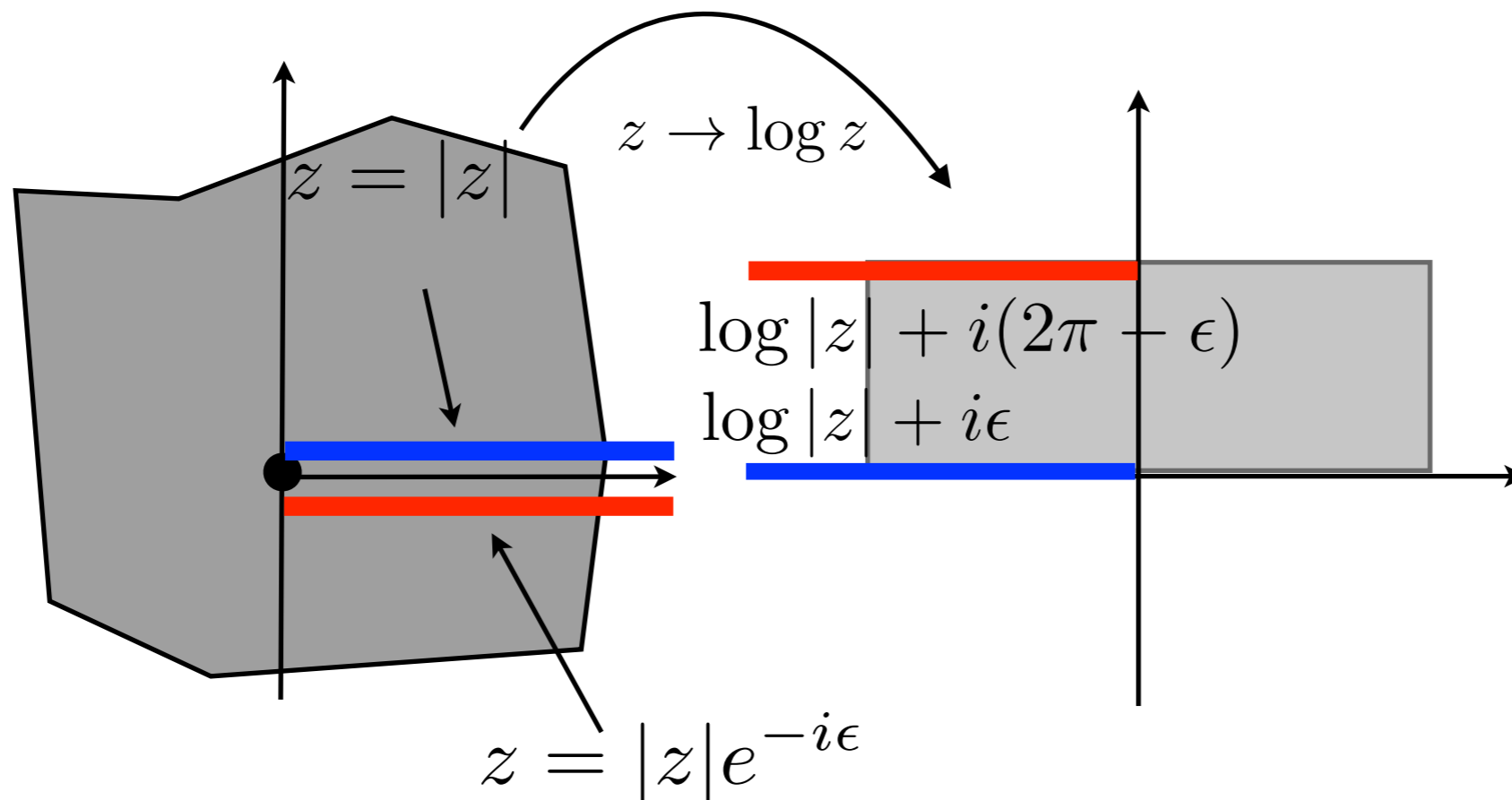

Powers: $a^b = e^{b \log(a)}$ (for chosen branch of log)

$$\sqrt{z} = e^{\frac{1}{2} \log(z)} = \sqrt{|z|} e^{[i \frac{\arg z}{2} + (\text{mod } i\pi)]}$$

for example: using the principal branch ($-\pi \leq \arg z < \pi$)

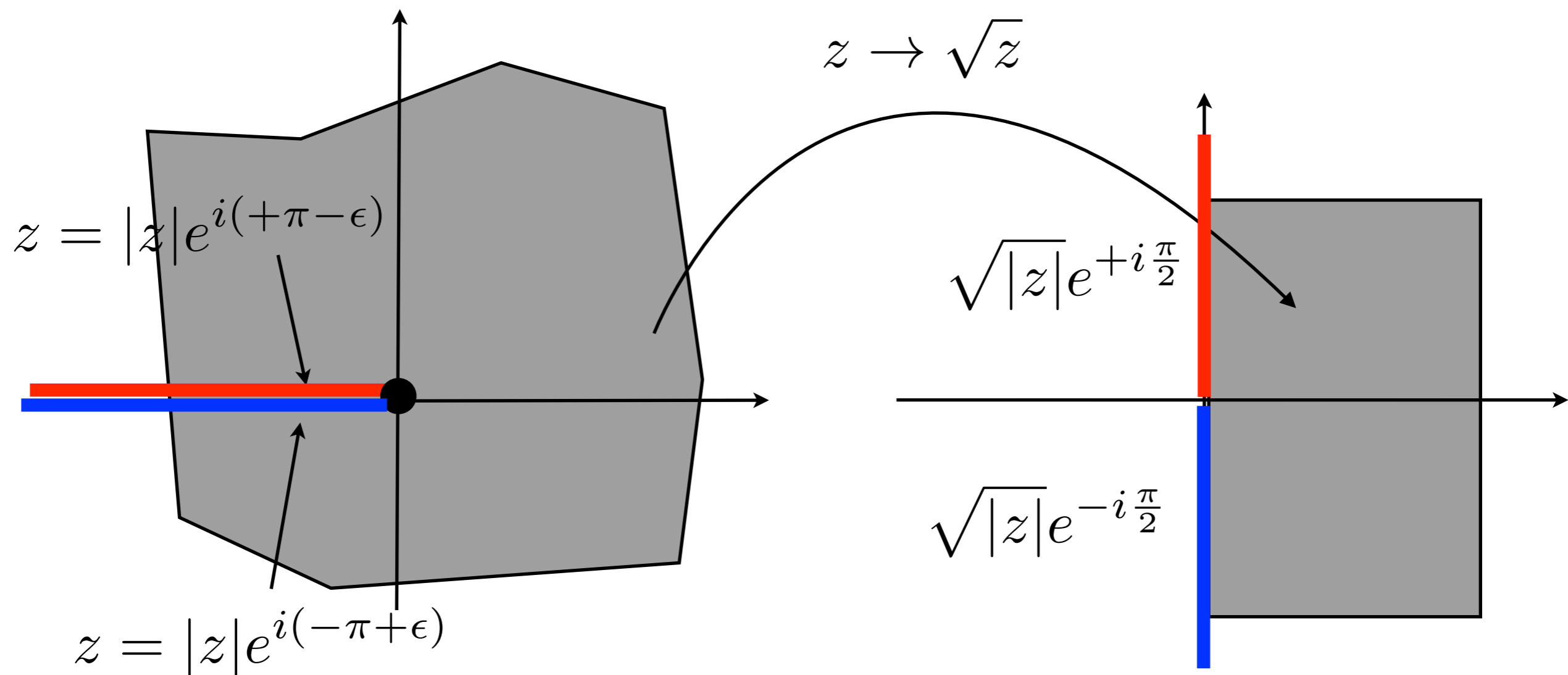

... or using the $[0, 2\pi)$ branch

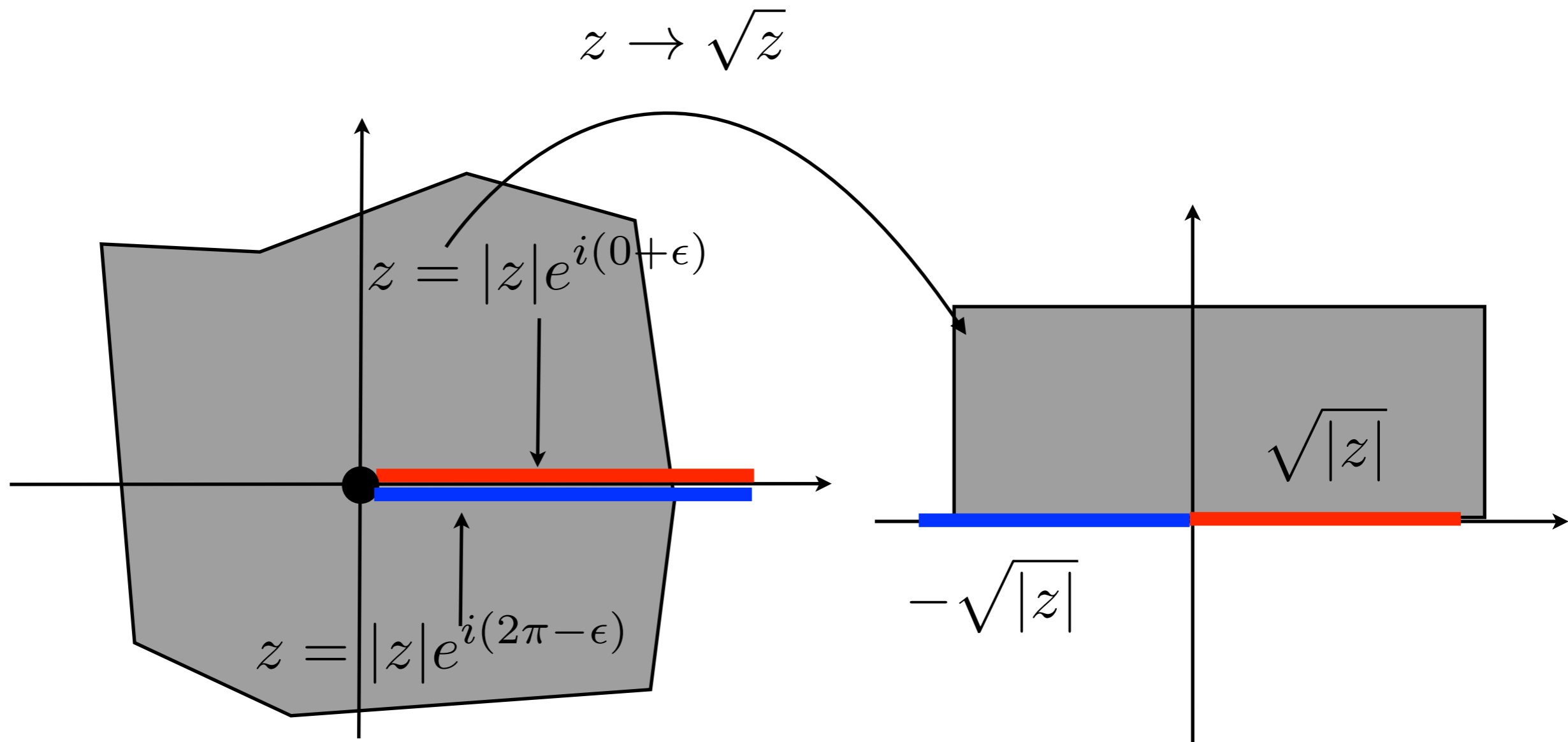

function has different value when evaluated above vs below a branch line:

$$\lim_{\delta z \rightarrow 0} [f(z + \delta z) - f(z - \delta z)] \equiv \text{Dis. } f(z) \neq 0$$

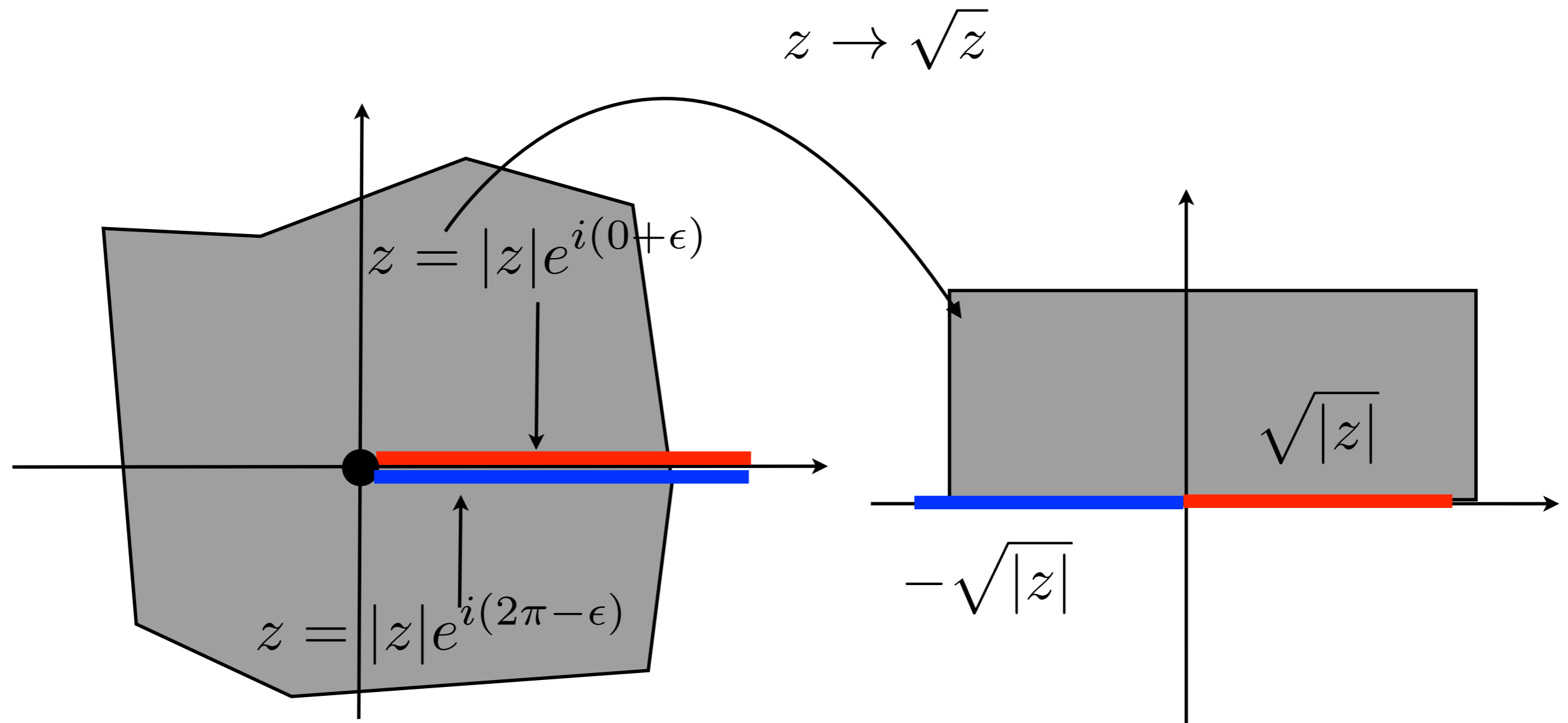

$$\text{Dis. } \sqrt{z} = 2\sqrt{z} \text{ for } z \text{ real and positive}$$

Composite functions

the key is to define one-to-one mapping which requires specification of branch lines

for example $z \rightarrow \sqrt{z^2 - 1}$ has two branch points and one needs to define orientation of two branch lines

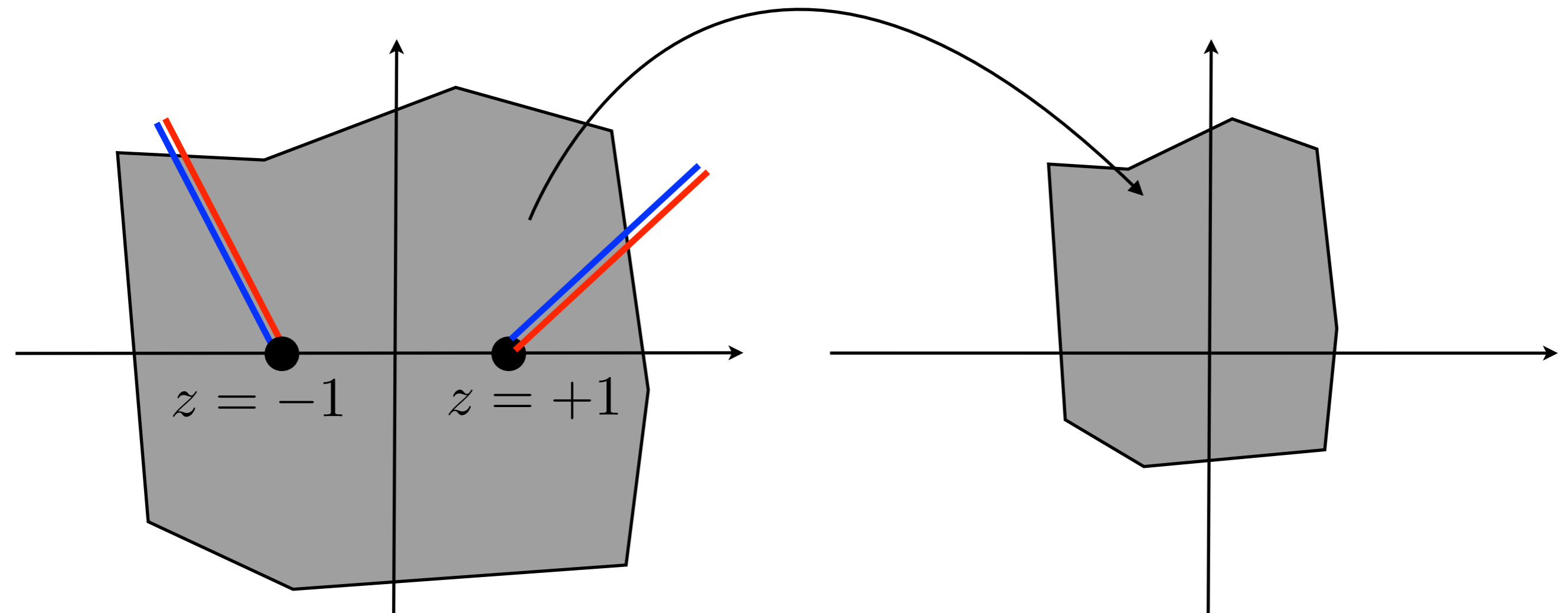

A. $z \rightarrow \sqrt{z^2 - 1}$
 $= \sqrt{z - 1}\sqrt{z + 1}$

and use principal branches

$$\sqrt{z^2 - 1} = \sqrt{r_1 r_2} e^{i \frac{\phi_1 + \phi_2}{2}}$$

$$\phi_2 \in [-\pi, \pi)$$

$$r_1, r_2 = |z - 1|, |z + 1|$$

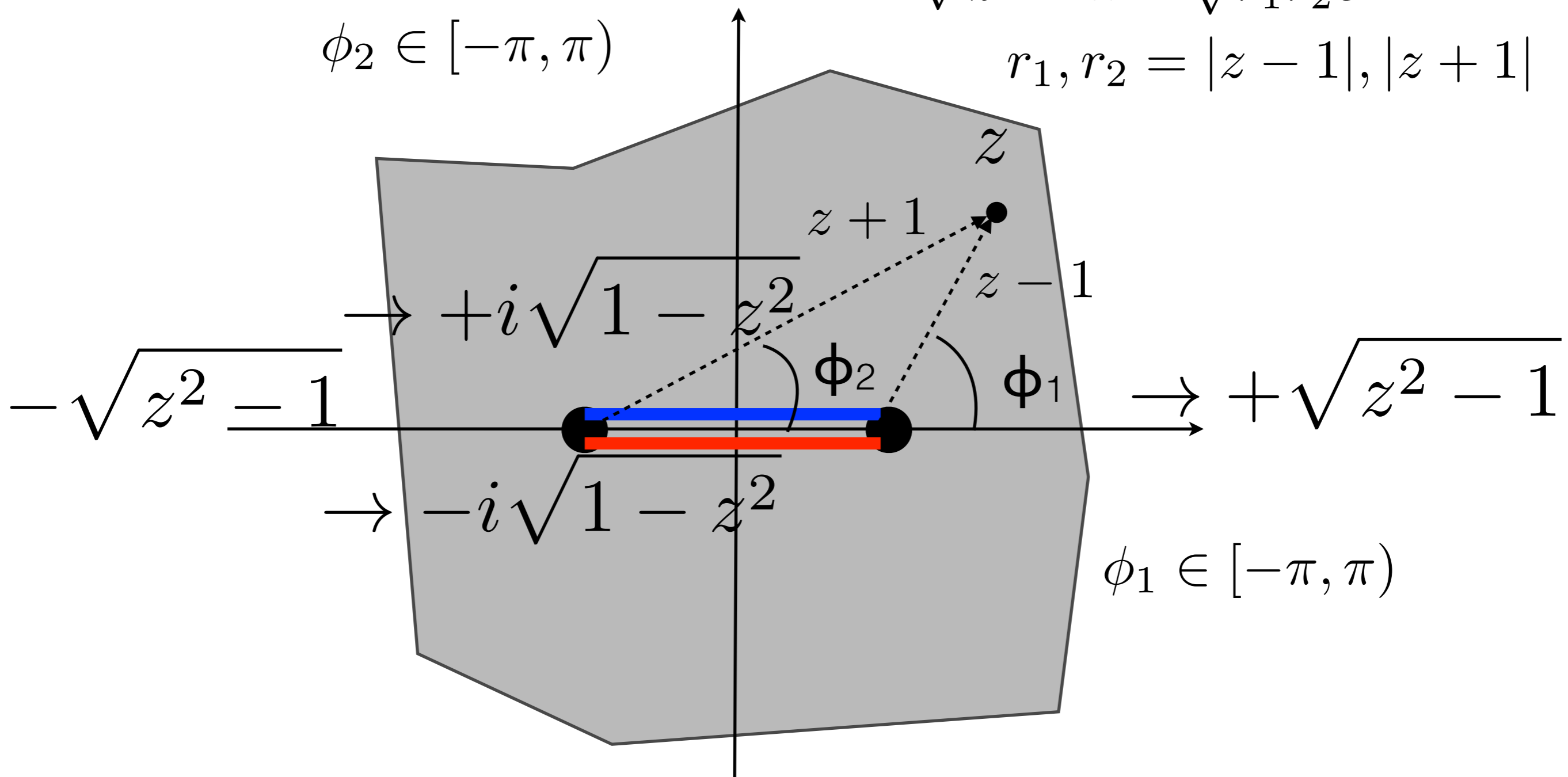

B. $z \rightarrow \sqrt{z^2 - 1}$

$$\sqrt{z^2 - 1} = \sqrt{r_1 r_2} e^{i \frac{\phi_1 + \phi_2}{2}}$$

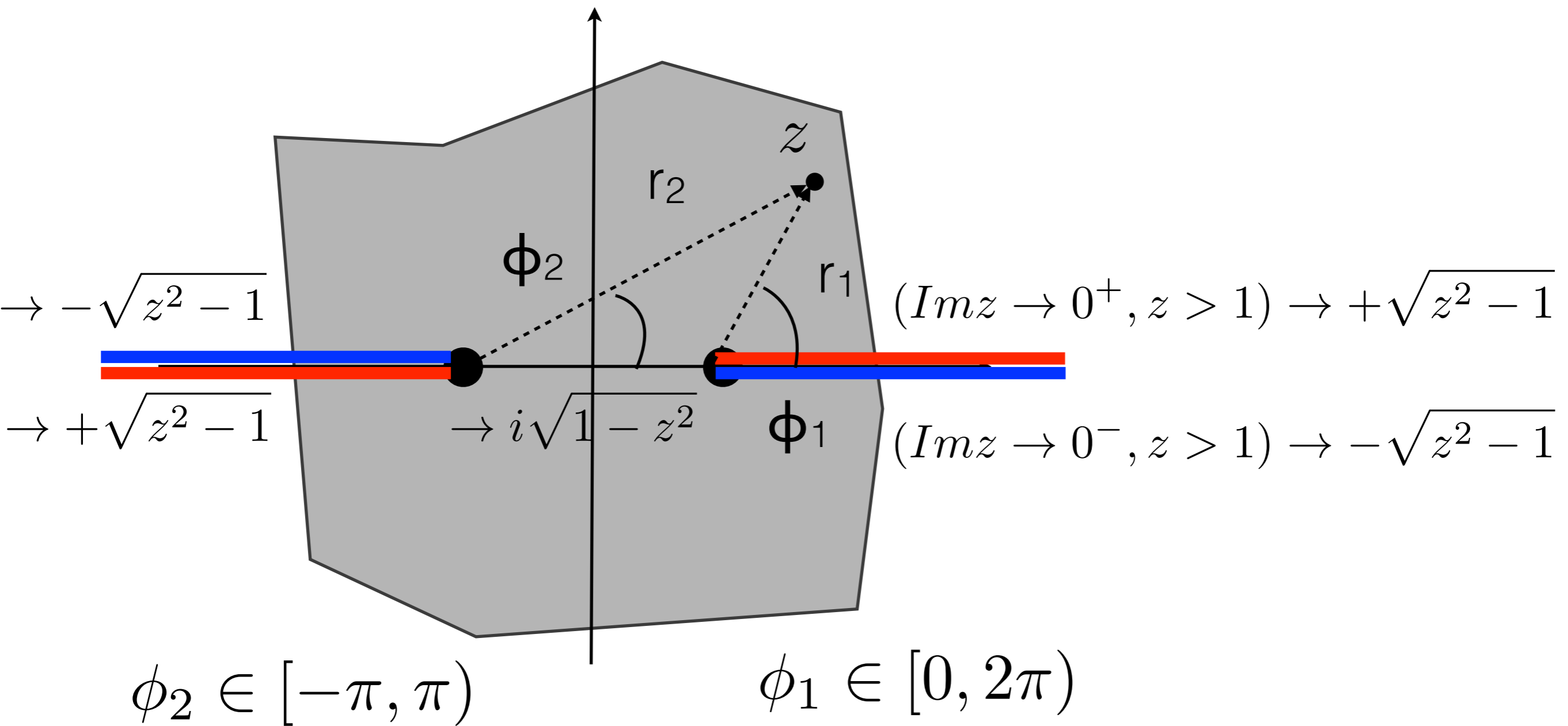

These two examples define different complex functions
which on the real axis relate to the real function

$$\pm \sqrt{x^2 - 1}$$

Which one to use depends on a specific application
(more later)

Complex functions: Riemann sheets

Is there a definition of a multivalued function which does not require branch cuts. (Georg Riemann, PhD. 1851)

Example: $z \rightarrow \log z$

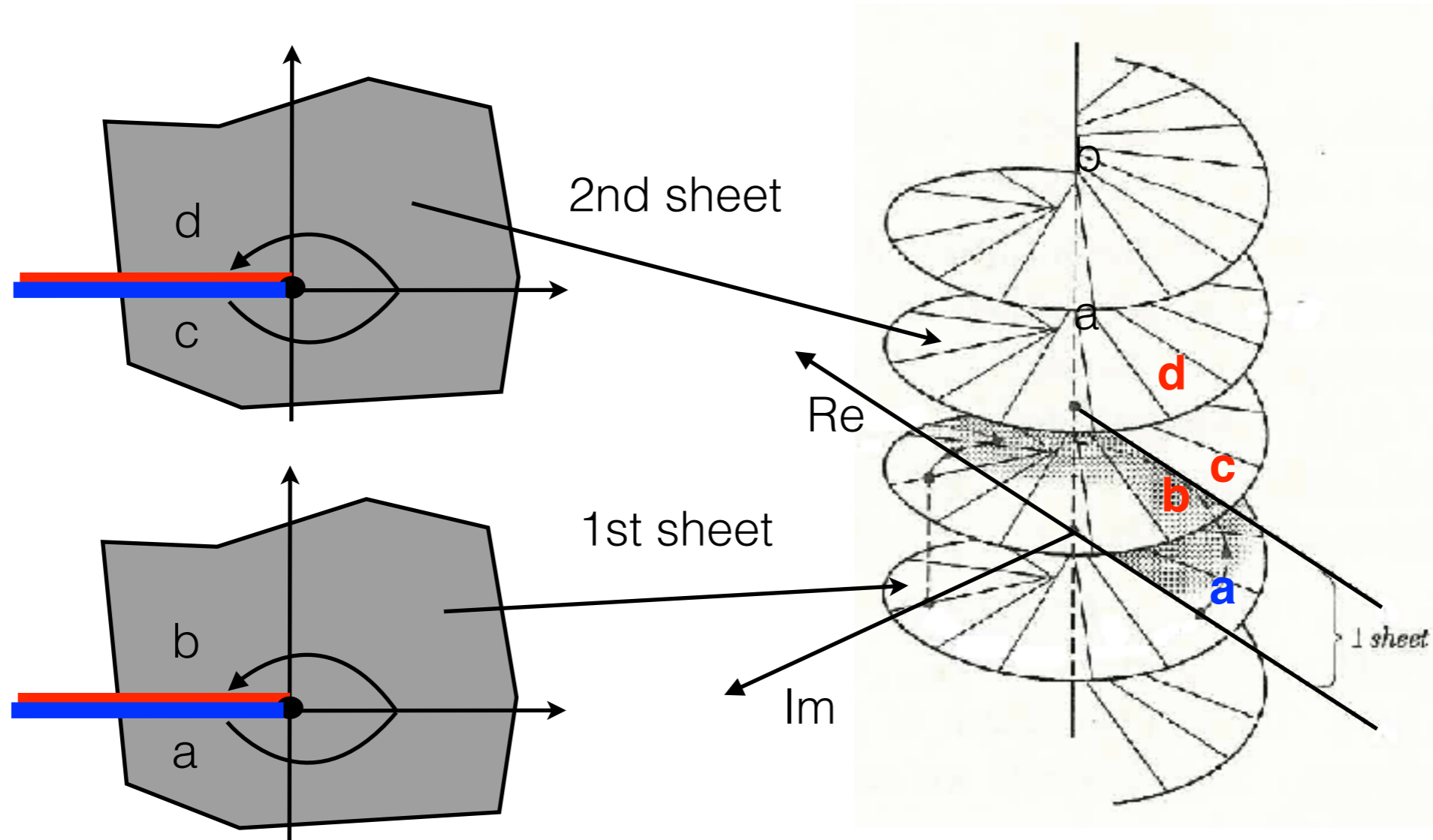

When z moves from a to b $\arg(\text{Im } \log)$ changes from 0 to 2π .

The 2nd Riemann sheet is a copy of the z -plane attached ("glued") at the branch line, such that c (on the 2nd sheet, infinitesimally below real axis) is close to b (on the 1st sheet, just above the real axis).

Riemann sheet for $z \rightarrow \sqrt{z}$

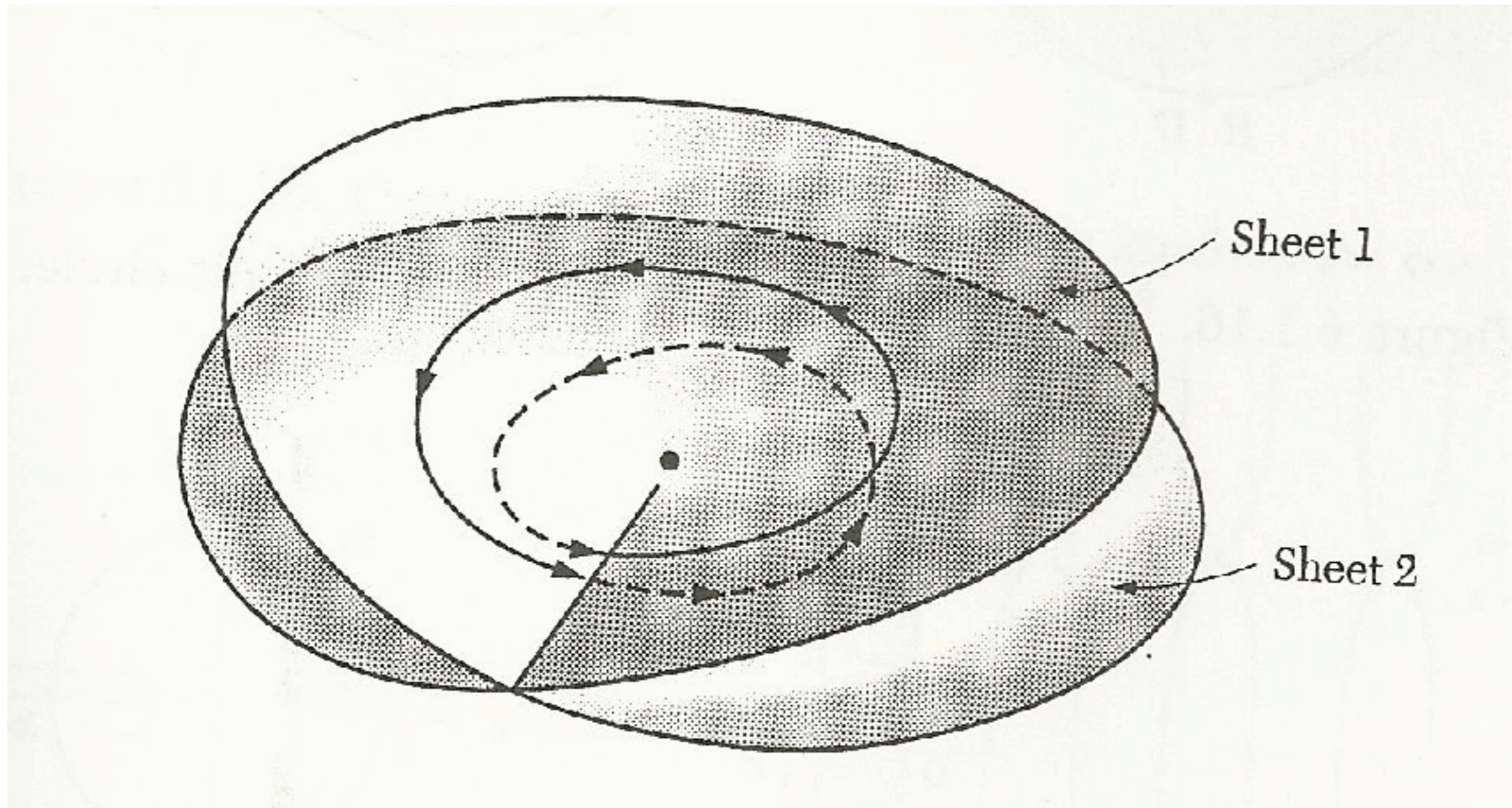

Riemann construction: change the “shape” (Riemann sheet) of the “input” complex plane z , so that $f(z)$ is single-valued when defined on this modified “shape”

Examples:

show that $\cos z = \frac{1}{2}$ has only real solutions

Find all values of i^i

show that $\sin(z_1 + z_2) = \sin z_1 \cos z_2 + \sin z_2 \cos z_1$

Show that under $z \rightarrow \sin(z)$ lines parallel to the real axis are mapped to ellipses and that lines parallel to the imaginary axis are mapped to hyperbolas

Complex Calculus:

Preliminaries:

Definitions (continuity, limits) similar to functions of real variables, except that variations “ Δ ” can be taken anywhere along paths in the complex plane

e.g. continuity: $f(z)$ is continuous at z_0 if $\lim_{z \rightarrow z_0} f(z) = f(z_0)$

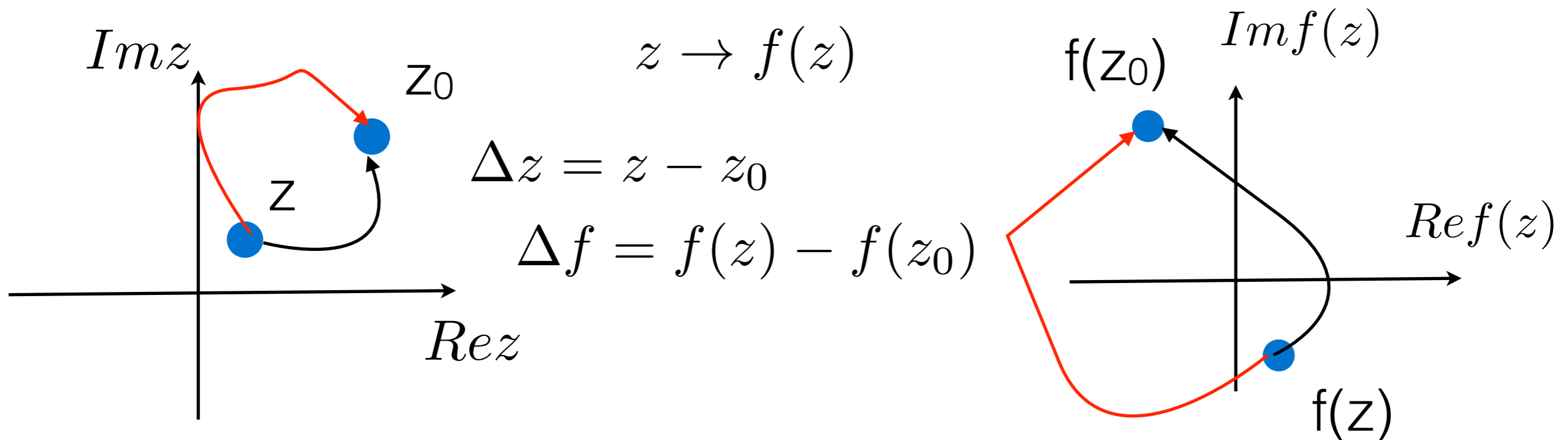

$f(z)$ is a function of two real variables since $z = x + iy$. However, $f(z)$ refers to a function of z and not of independent variables. The whole point is to explore the consequences of this “unique” combination of x and y “coupled” by i

Differentiation: $f(z)$ is differentiable (holomorphic) if $\lim_{z \rightarrow z_0} \frac{f(z) - f(z_0)}{z - z_0} \equiv f'(z_0)$ exists

write $z = x + iy$ and $f(z)$ as $f(z) = u(x,y) + i v(x,y)$. Since the procedure of taking the limit in definition of $f'(z_0)$ is independent of the path taken in $z \rightarrow z_0$, you can take two independent paths e.g. path 1: $x = x_0 + \varepsilon, y = y_0$ and path 2: $x = x_0, y = y_0 + \varepsilon$: Cauchy relations:

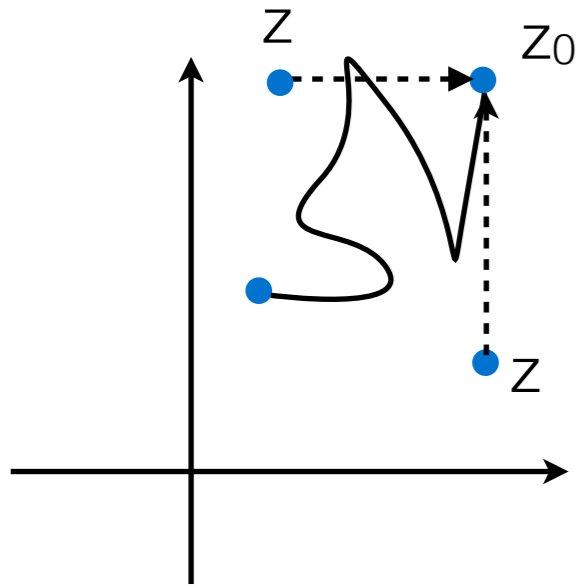

$$\frac{\partial u}{\partial x} = \frac{\partial v}{\partial y}, \quad \frac{\partial u}{\partial y} = -\frac{\partial v}{\partial x}$$

This implies $\Delta u = \Delta v = 0$
 where Δ is 2-dim Laplacian
 u, v : harmonic functions

Infinity: on the real axis there are two (axis is oriented) but on the complex plane (calculus) there is no preferred direction: There is only ONE infinity (somewhat counter intuitive) $w = 1/z$

$$\frac{df}{dz} \Big|_{z=\infty} = -\frac{1}{w^2} \frac{df}{dw} \Big|_{w=0}$$

Stereographic projection $S^2 \rightarrow (x,y) = z$

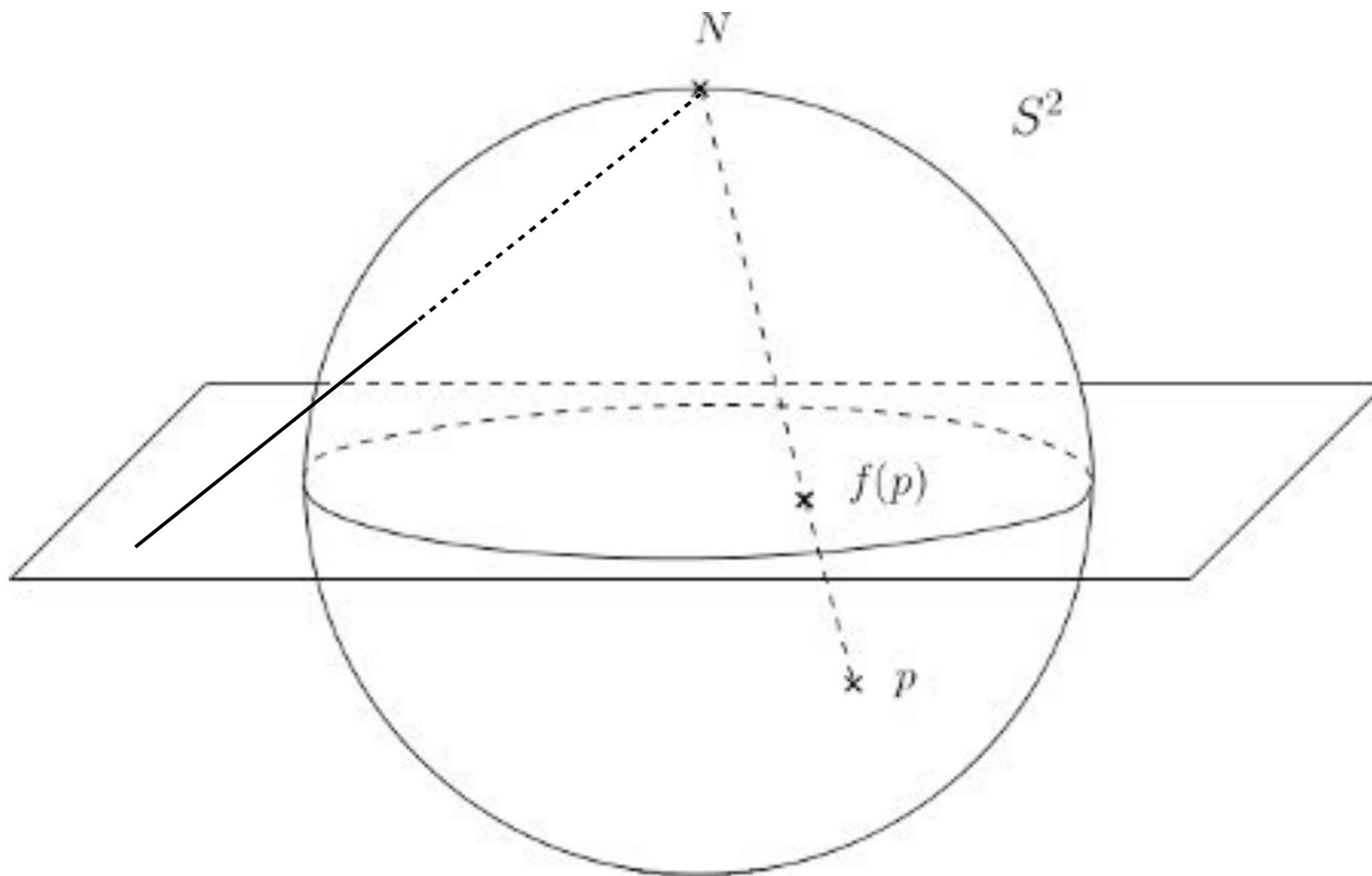

North pole is mapped at the point at infinity

Applications:

Explore the connection between harmonic functions and holomorphic functions

Harmonic functions represent solutions to physical problems relating “flows” to “sources”

e.g. mass density vs. velocity flux,
temperature vs heat flow,
electric charge vs electric field
magnetic charge (monopole) vs magnetic field
etc.

Heat flow due to Temperature gradient

$$\text{Temperature gradient} = \vec{\nabla}T$$

$$\text{Energy density} = \rho cT$$

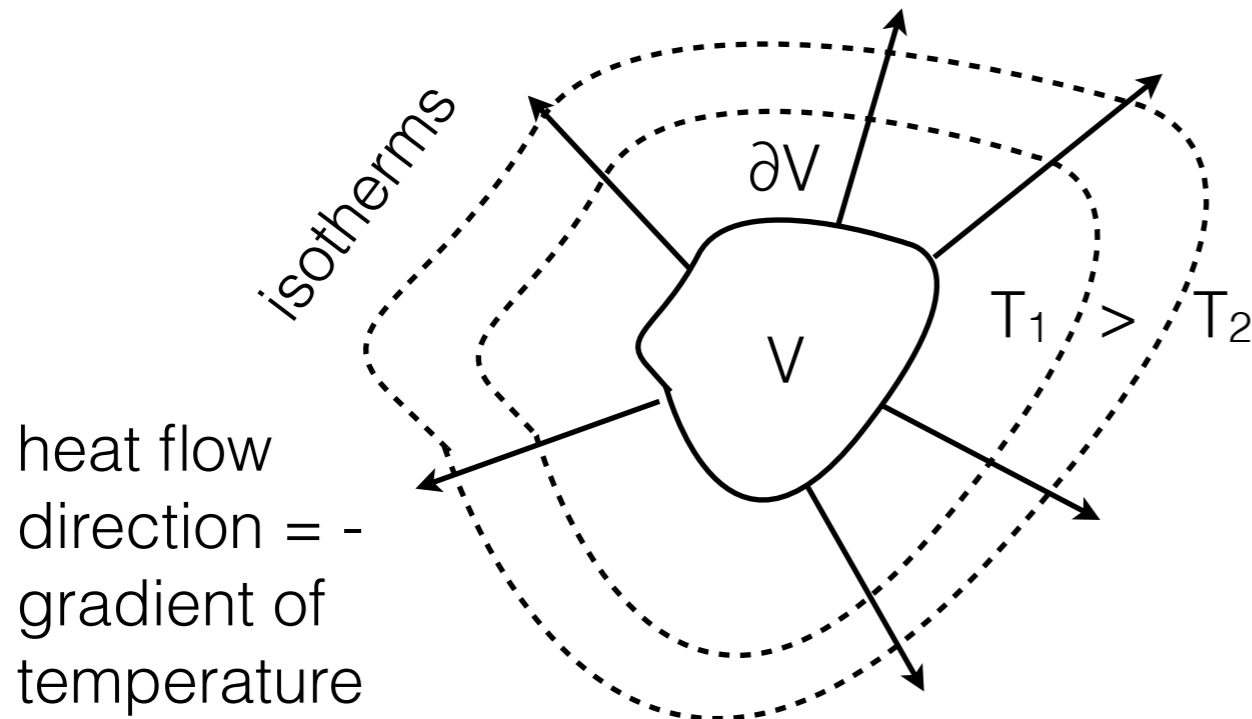

$$-\frac{d}{dt} \int_{\text{Volume}} \text{Energy density } dV = \text{Conductivity} \int_{\partial \text{Volume}} -\text{Temperature gradient} \cdot d\vec{S}$$

$$\int_V \vec{\nabla} \cdot \vec{f} dV = \int_{\partial V} \vec{f} \cdot d\vec{S}$$

Gauss's law:

$$\rho c \frac{\partial T}{\partial t} = \kappa \Delta T$$

if T is kept constant in time, then spacial distribution is a harmonic function $\Delta T=0$

For a given isotherm, spacial distribution of temperature can be found by "guessing" a complex function whose real (or imaginary) part has the prescribed value on a line segment (isotherm)

Electric charge vs Electric field (or potential)

$$\int_{Volume} \text{Charge density } dV = \epsilon_0 \int_{\partial Volume} \text{Electric field} \cdot d\vec{S}$$

Electric field = - Potential gradient = $-\vec{\nabla}\phi$

Gauss's law: $\int_V \vec{\nabla} \cdot \vec{f} dV = \int_{\partial V} \vec{f} \cdot d\vec{S}$

$$\Delta\phi = -\frac{\rho}{\epsilon_0}$$

“guess” complex function to represent ϕ
 any holomorphic function solves some
 problem in electrostatics e.g.

$$f(z) = z^2 = (x^2 - y^2) - 2ixy$$

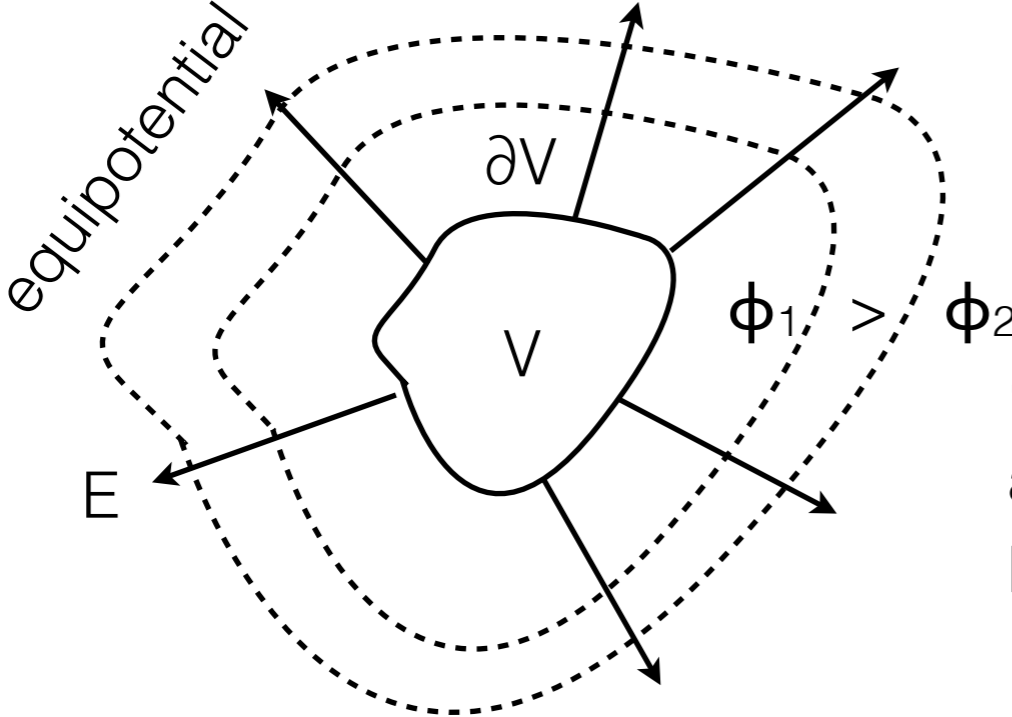

```
contourplot(x·y, x=-1..1, y=-1..1);
```

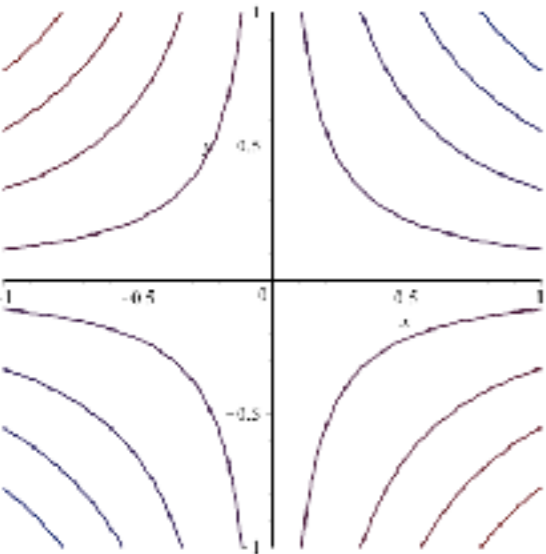

```
contourplot(x^2 - y^2, x=-1..1, y=-1..1);
```

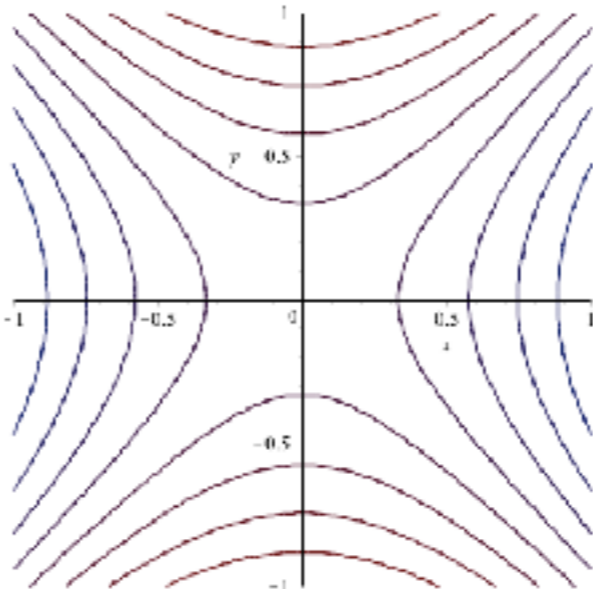

Potential of a single charge in 2 dim

```
contourplot( { log(x^2 + y^2), arctan(y/x) }, x=-1..1, y=-1..1 );
```

$f(z) = \log z$: holomorphic
except at $z=0$

$$\Delta \log r = 2\pi \delta^2(\vec{r})$$

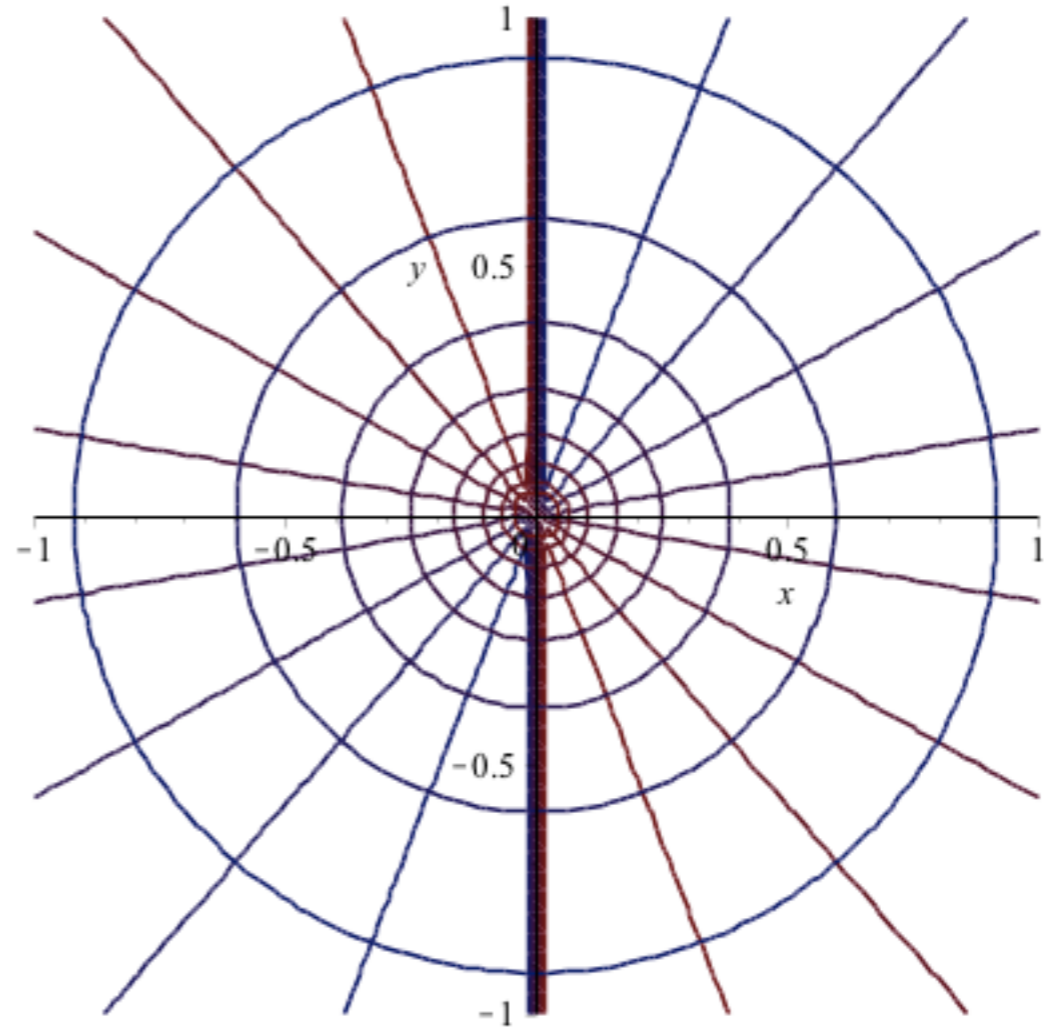

$$\int_{S_1} \vec{\nabla} \log r \cdot d\vec{S} = \int_0^{2\pi} d\phi \frac{\vec{r} \cdot \vec{n}}{r} = 2\pi = \int dV \Delta \log r = \int_{S_2} dx dy \Delta \log r$$

$$\vec{\nabla} \log r = \frac{\vec{r}}{r^2}$$

Intermezzo: Magnetic monopoles

EM Fields in a tensor form

$$F^{\mu\nu} = \begin{pmatrix} 0 & -E_x & -E_y & -E_z \\ E_x & 0 & -H_z & H_y \\ E_y & H_z & 0 & -H_x \\ E_z & -H_y & H_x & 0 \end{pmatrix} \quad \bar{F}^{\mu\nu} = \frac{1}{2} \varepsilon^{\mu\nu\alpha\beta} F_{\alpha\beta} = \begin{pmatrix} 0 & -H_x & -H_y & -H_z \\ H_x & 0 & E_z & -E_y \\ H_y & -E_z & 0 & E_x \\ H_z & E_y & -E_x & 0 \end{pmatrix}$$

Maxwell equations

$$\partial_\nu F^{\nu\mu} = j^\mu \quad \partial_\nu \bar{F}^{\nu\mu} = j_{mag}^\mu$$

$$\partial_\nu F^{\nu\mu} = j^\mu \rightarrow \vec{\nabla} \cdot \vec{E} = \rho \quad -\partial_t \vec{E} + \vec{\nabla} \times \vec{H} = \vec{j}$$

$$\partial_\nu \bar{F}^{\nu\mu} = j_{mag}^\mu \rightarrow \vec{\nabla} \cdot \vec{H} = 0 \quad -\partial_t \vec{H} - \vec{\nabla} \times \vec{E} = 0$$

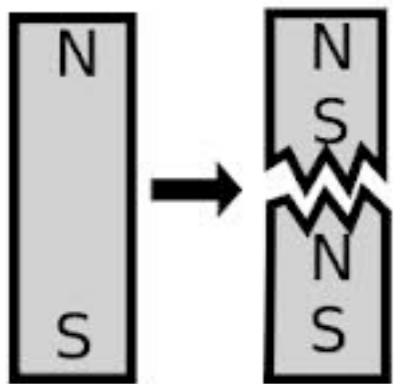

Instead of isolated charge, think of a very long magnet/solenoid

$$\vec{H} \equiv \vec{H}_{pole} - \vec{H}_{string}$$

$$\vec{H}_{pole} = \vec{\nabla} \times \vec{A} + \vec{H}_{string}$$

$$\vec{A} = -\frac{g}{4\pi} \vec{\nabla} \times \int_L \frac{d\vec{R}}{|\vec{r} - \vec{R}|}$$

Since $\vec{\nabla} \cdot \vec{H} = 0$ it is possible

to introduce A associated with H

For infinitesimally thin solenoid ("string") its magnetic field is along its direction

$$\vec{H}_{string} = g \int_L \delta(\vec{r} - \vec{R}) d\vec{R}$$

$$\vec{H}_{pole} = \frac{g}{4\pi} \frac{\vec{r}}{r^3}$$

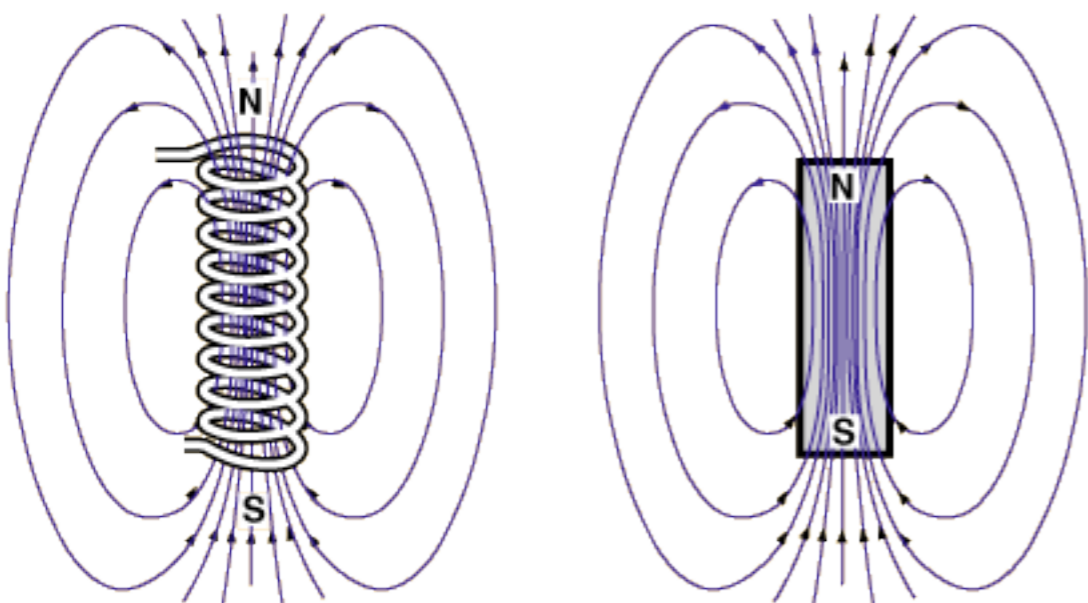
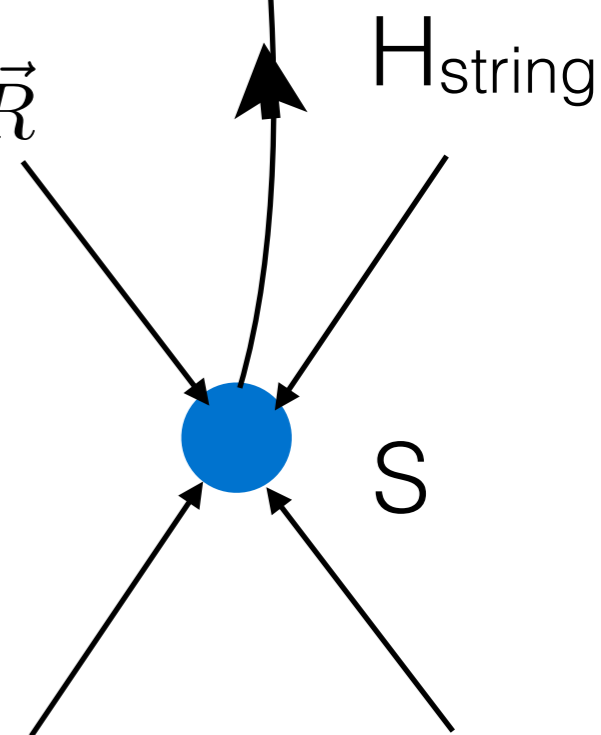
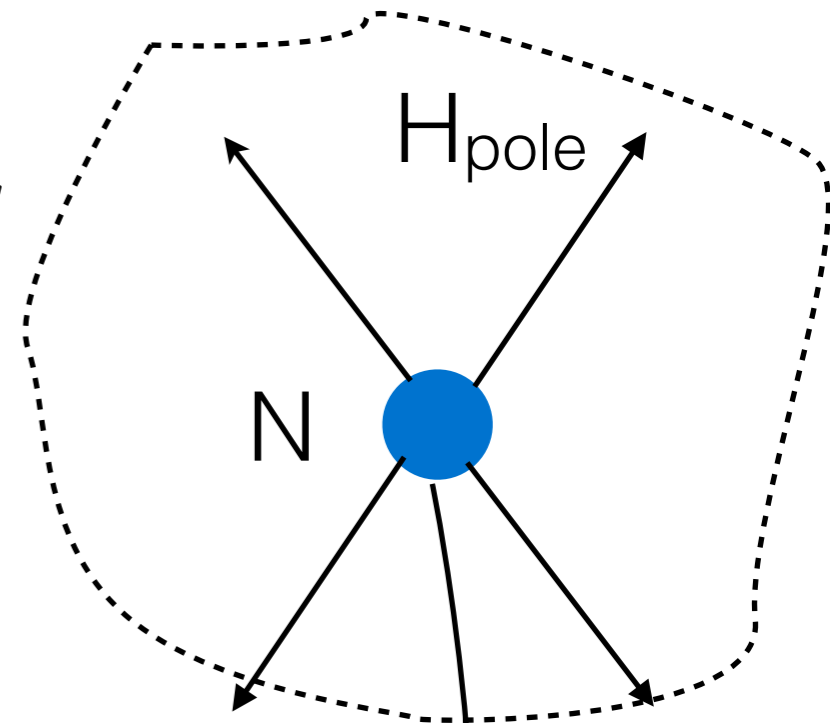

Monopoles in QCD $\vec{B} \rightarrow \vec{B}^a, a = 1, \dots, N_c^2 - 1$ QCD : $N_c = 3$
 (simplify using $N_c=2$)

$$B_i = \partial_j A_k - \partial_k A_j \rightarrow B_i^a = \partial_j A_k^a - \partial_k A_j^a - \epsilon_{abc} \epsilon_{ijk} A_j^b A_k^c$$

Maxwell (YM) equations are nonlinear

$$\partial^\nu F_{\nu\mu}^a + \epsilon_{abc} A_\nu^b F_{\mu\nu}^c = 0 \quad B_i^a \sim \frac{x_i x^a}{r^4}$$

and even in absence of external source have monopole-like solutions (Wu-Yang monopoles)

Unfortunately they are singular (infinite energy) (YM equations have no non-trivial classical solutions with finite energy (eg. solitons) or classical glueballs do not exist (Coleman))

But lattice “regularizes” short distances: and monopoles can be found in lattice simulations

QCD on the lattice : unbound vector potential becomes replaced by an angular variable:

” Link Variable ” = $e^{i \int_n^{n+1} d\vec{l} \cdot \vec{A}} \rightarrow e^{iaA} \in SU(N_c)$

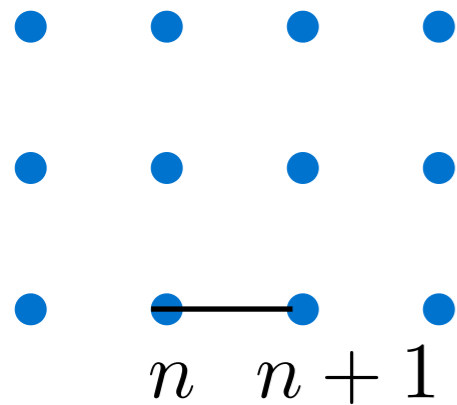

Here $A = A^a T^a$ with T generators of $SU(N_c)$ but consider a simpler theory: QED in 2 dim ($N_c = 0$ and $A^a \rightarrow A =$ vector potential). Then at each lattice link one defines $\exp(i a A)$ (along the link) complex number of unit length. Consider even simpler model, by replacing a vector A by a scalar $\exp(i a A) \rightarrow \exp(i a \phi)$. The simplest interaction which a) couples next-neighbor (eg. local in continuum limit) and b) preserves the angular nature of a ϕ is of the type

$$1 - \cos(a\phi_x - a\phi_{x+\delta})$$

$$H = \frac{1}{a^2} \sum_{x,\delta} [1 - \cos(a\phi_x - a\phi_{x+\delta})] \rightarrow \frac{1}{2} a^2 \sum_{x,\delta} \frac{(\phi_x - \phi_{x+\delta})^2}{a^2} \rightarrow \frac{1}{2} \int dx dy (\partial_i \phi)^2$$

Partition function is then given by: $Z = \int_{-\pi}^{\pi} \prod_x \frac{d\phi_x}{2\pi} \exp(-\beta \sum_{x,\delta} [1 - \cos(\phi_x - \phi_{x,\delta})])$

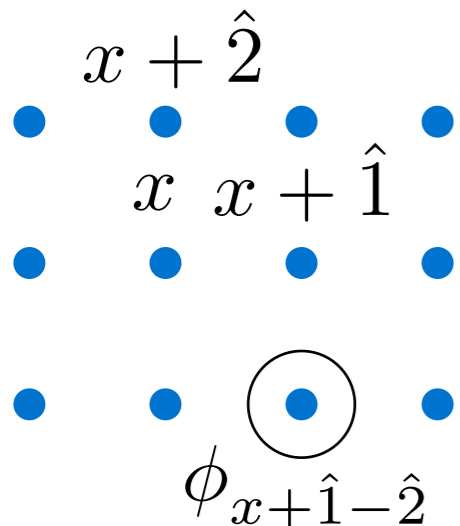

configurations are as important

$$\phi_{x+\delta} \sim +\pi - \epsilon \quad \phi_{x+\delta} \sim -\epsilon$$

$$\phi_x \sim -\pi + \epsilon \quad \phi_x \sim +\epsilon$$

There could give “fracture lines” between lattice sites across which ϕ changes by 2π

- $\phi \sim +\pi$ ● $\phi \sim -\pi$
- $-\pi < \phi < +\pi$

high temperature (small- β)

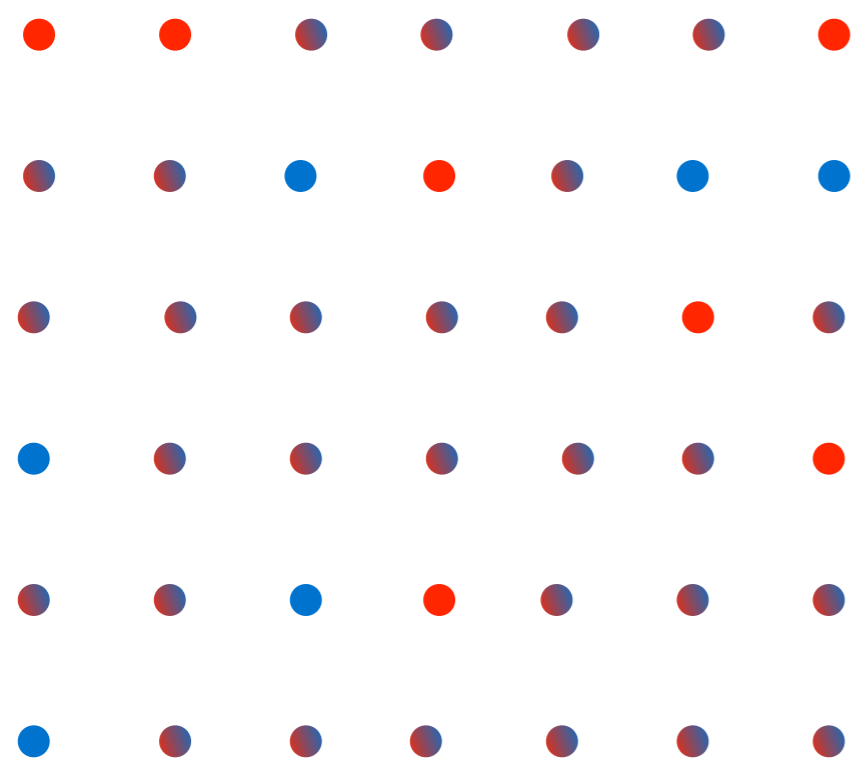

system is disordered

low temperature (large $-\beta$)

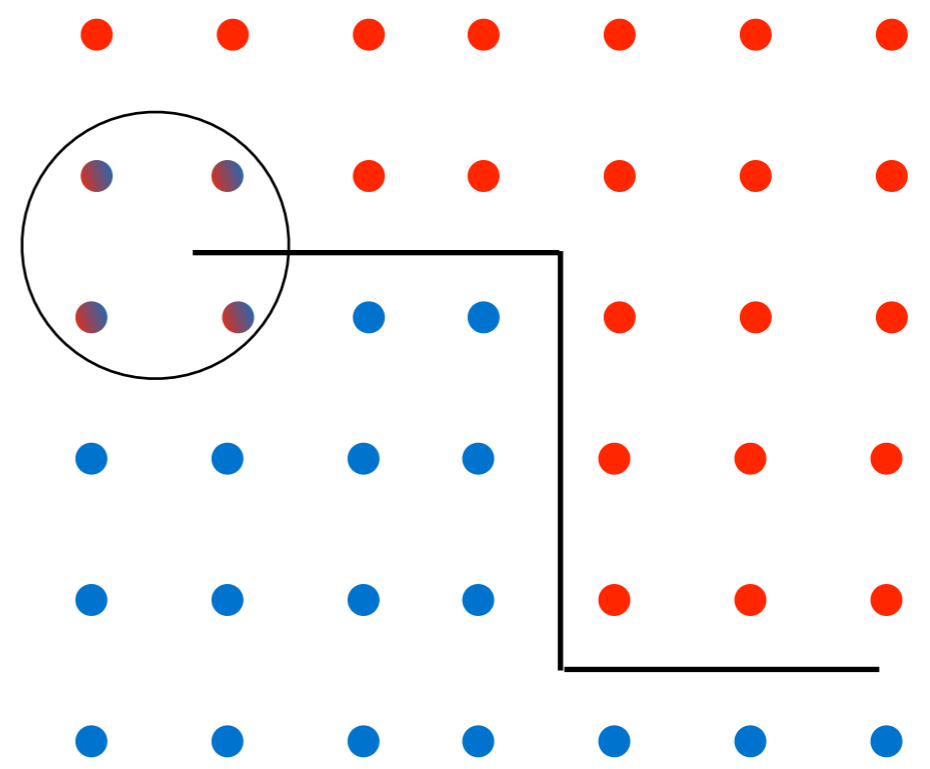

system is ordered

looks like a monopole with a string !

region of contribution to the action
due to "fraction"

In the continuum limit $H = \frac{1}{2} \int dx dy (\partial_i \phi)^2$ and minimum

of the energy satisfies $\Delta \phi = 0$. Once we have introduced a set of monopoles (in 2dim called vortices) placed at points x_a with strength q_a it means that we have introduced a multivalued ϕ which changes by $2\pi q_a$ every time we go around a vortex. In this case the harmonic function solution to the 2dim Laplace equation has the form

$$\phi = \sum_{a=1}^N q_a \text{Im} \log(z - z_a)$$

with $z_a = x_a + iy_a$ being the location of the vortex

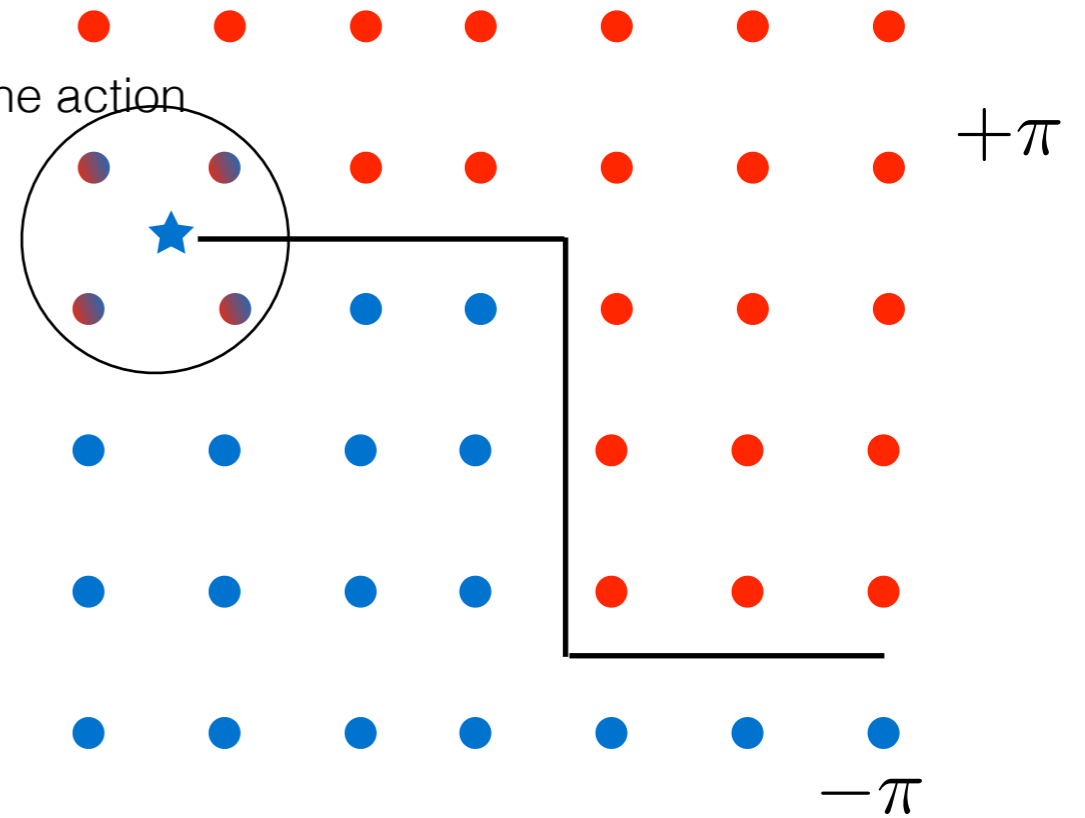

$$N = 2 \quad q_1 = 1 \quad z_1 = -1 + 0i$$

$$q_2 = -1 \quad z_2 = +1 + 0i$$

String: $-1 < x < +1$

$$N = 1 \quad q = 1 \quad z = -1 + 0i$$

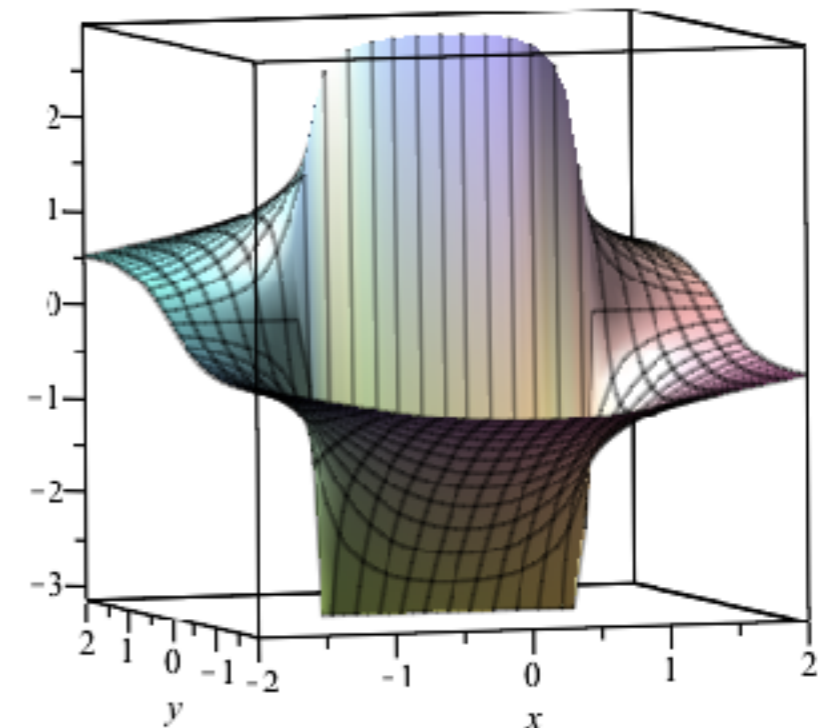
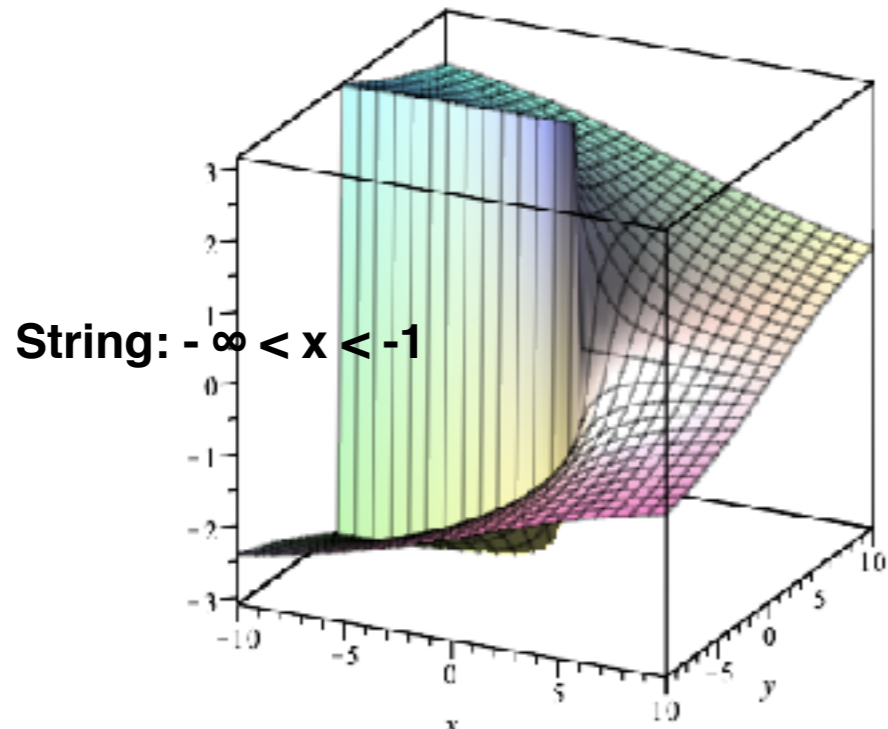

QCD: Confinement due to percolating (center) vortices

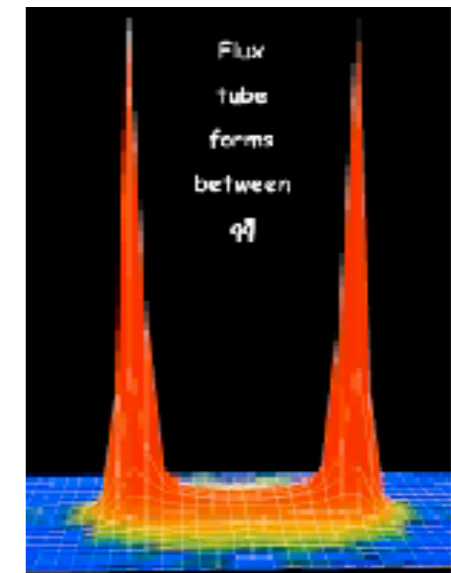
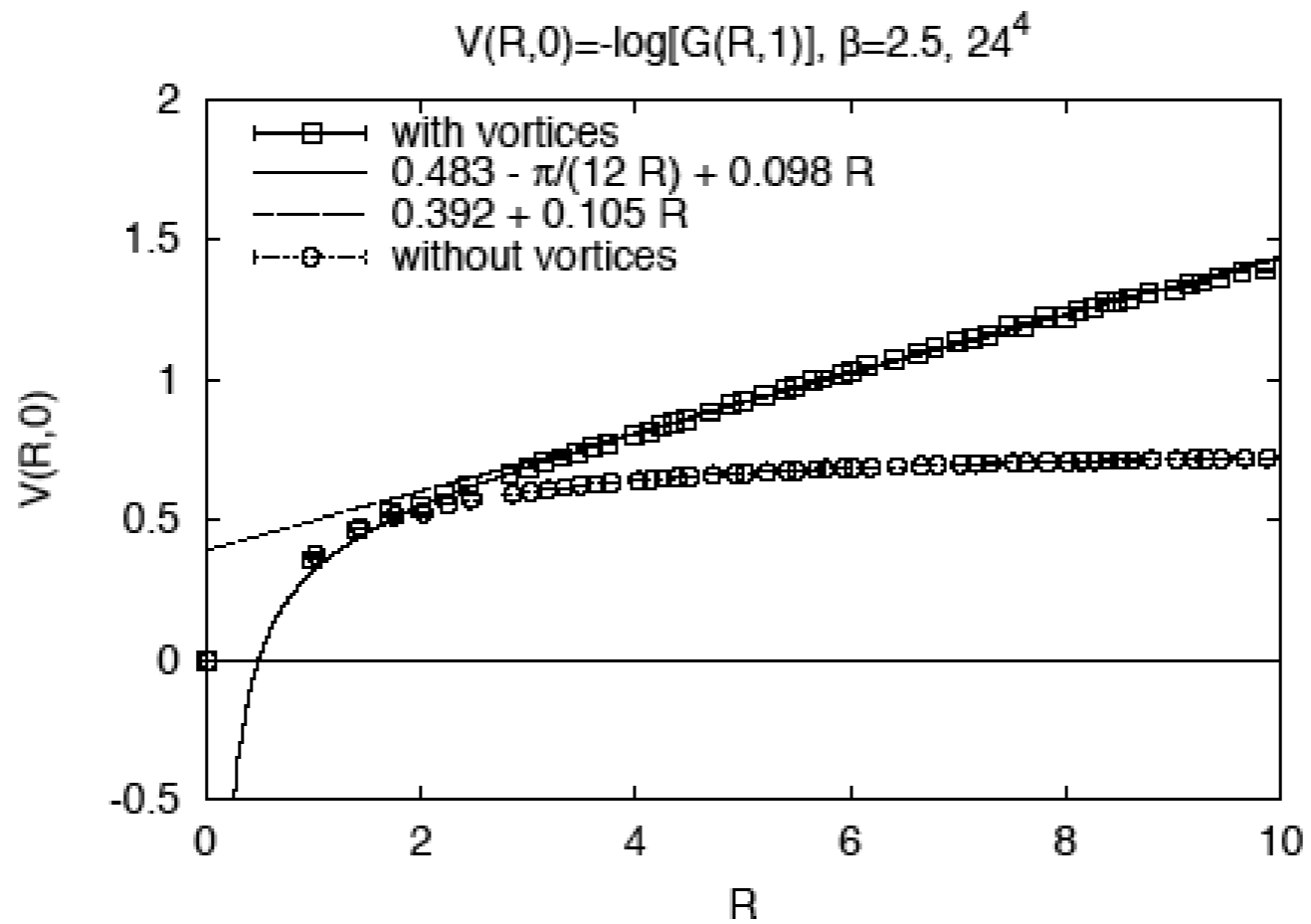
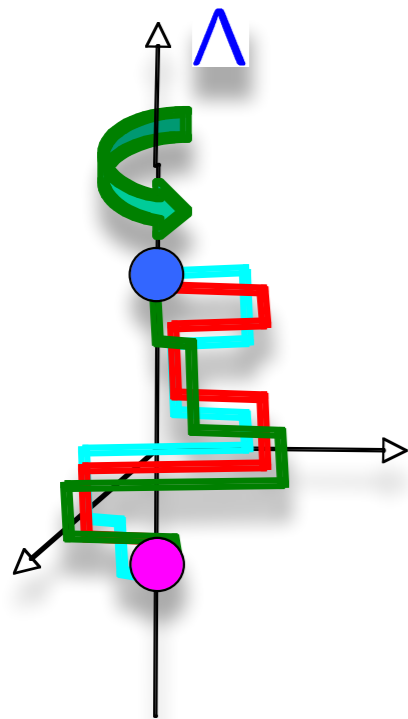
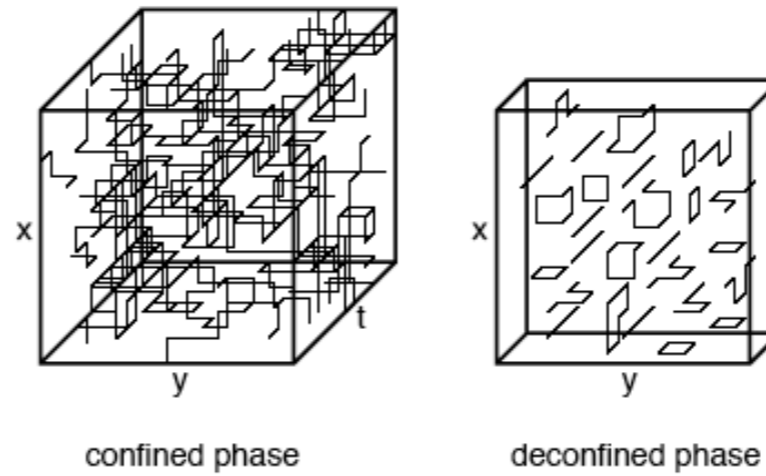

Complex calculus:
Complex integrals

Real calculus $\int_a^b dx f(x)$

Complex calculus $\int_C dz f(z)$ $C =$ curve in z -plane

Line integrals: given a curve C in the complex plane parametrized by a real number $0 \leq t \leq 1$, $t \rightarrow z(t) = x(t) + iy(t)$ the integral of f over C is defined by

$$\int_C f(z) dz = \int_{t=0}^1 f(z(t)) \frac{dz}{dt} dt = \lim_{|\Delta z_n| \rightarrow 0, N \rightarrow \infty} \sum_{n=1}^N f(a_n) \Delta z_n$$

$\Delta z_n = z_n - z_{n-1}$ note: this is an ordered path

We can estimate the integral: if $|f(z)| \leq M > 0$ along C then

$$\left| \int_C f(z) dz \right| \leq Ms \quad \text{where } s \text{ is the length of the path}$$

$z(0) = z_0$ $z(1) = z_N$

Cauchy-Goursat theorem: If $f(z)$ is holomorphic in some region G and C is a closed contour (consisting of continuous or discontinuous cycles, double cycles, etc.) then

$$\oint f(z) dz = 0 \quad (\text{converse is also true})$$

Proof: according to Stoke's theorem

$$\int_S (\vec{\nabla} \times \vec{A}) \cdot d\vec{S} = \oint_C \vec{A} \cdot d\vec{l}$$

(e.g. Magnetic flux $\vec{B} \equiv \vec{\nabla} \times \vec{A}$ over open surfaces = circulation of vector potential over its boundary)

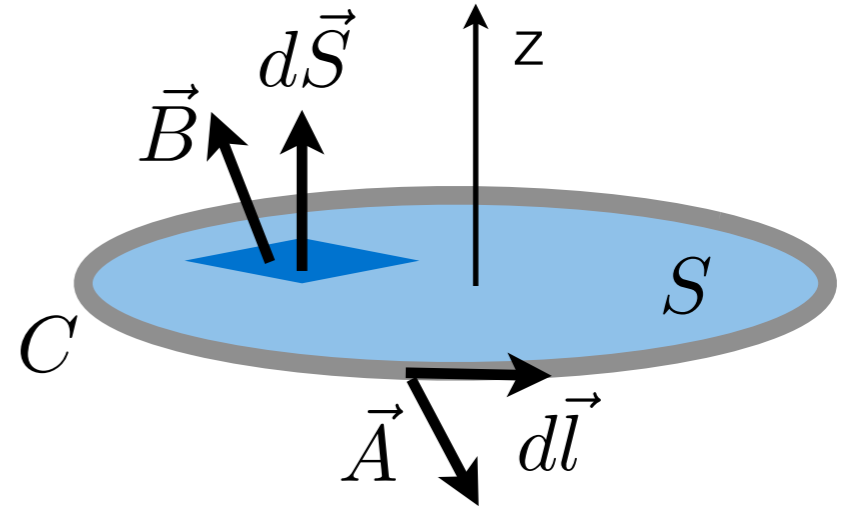

$$\int_S \left(\frac{\partial A_y}{\partial x} - \frac{\partial A_x}{\partial y} \right) dx dy = \oint (A_x dx + A_y dy)$$

(Cauchy relation for u,v)

use: $A_y = u(x,y)$, $A_x = v(x,y)$ then $\frac{\partial A_y}{\partial x} = \frac{\partial A_x}{\partial y}$ and l.h.s=0

$$\oint (v dx + u dy) = 0$$

use: $A_y = v(x,y)$, $A_x = -u(x,y)$ then $\frac{\partial A_y}{\partial x} = \frac{\partial A_x}{\partial y}$ and l.h.s=0

$$\oint (-u dx + v dy) = 0$$

$$\oint f(z) dz = \oint [u + iv][dx + idy] = \oint [u dx - v dy] + i \oint [v dx + u dy] = 0$$

The Cauchy integral formula: if $f(z)$ holomorphic in G , $z_0 \in G$, and C a closed curve (cycle), which goes around z_0 once in positive (counterclockwise) direction, then

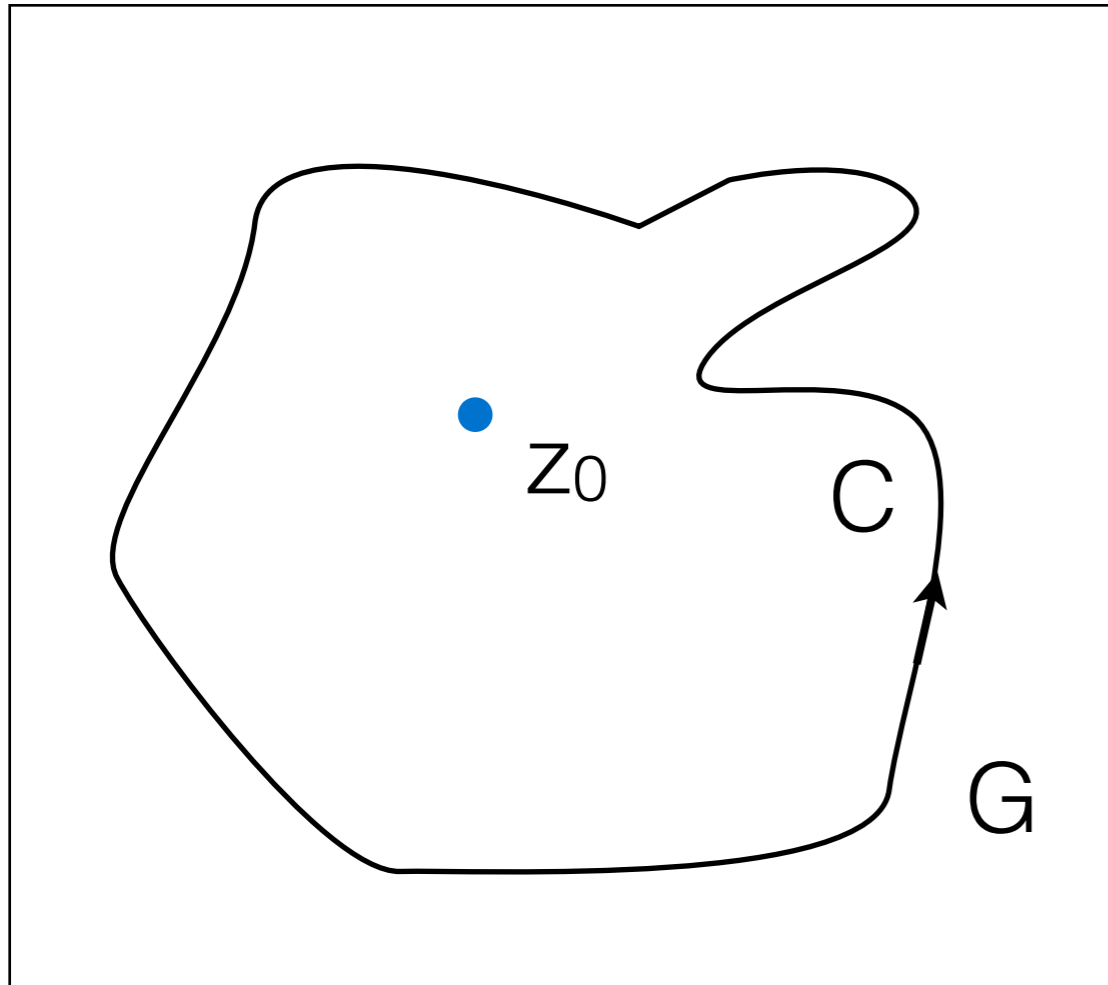

$$f(z_0) = \frac{1}{2\pi i} \oint_C \frac{f(z) dz}{z - z_0}$$

The Cauchy formula solves a boundary-value problem. The values of the function on C determine its value in the interior. There is no analogy in the theory of real functions. It is related though to the uniqueness of the Dirichlet boundary-value problem for harmonic functions (in 2dim)

Proof:

$$\lim_{\epsilon \rightarrow 0} C_\epsilon = C \quad \lim_{\epsilon \rightarrow 0} L_1 = -L_2$$

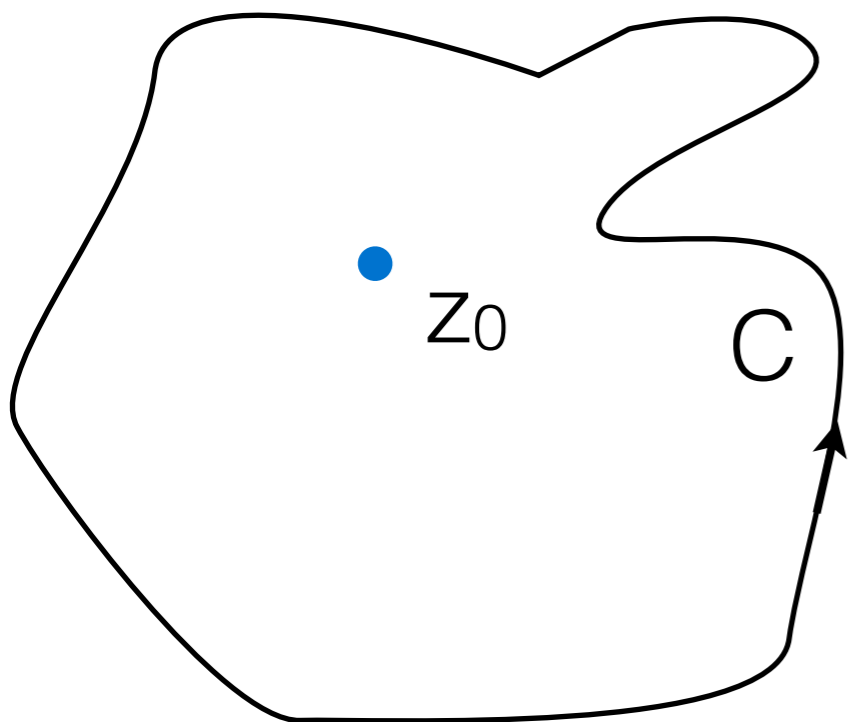

$$\oint_{C'} \frac{f(z) dz}{z - z_0} = 0$$

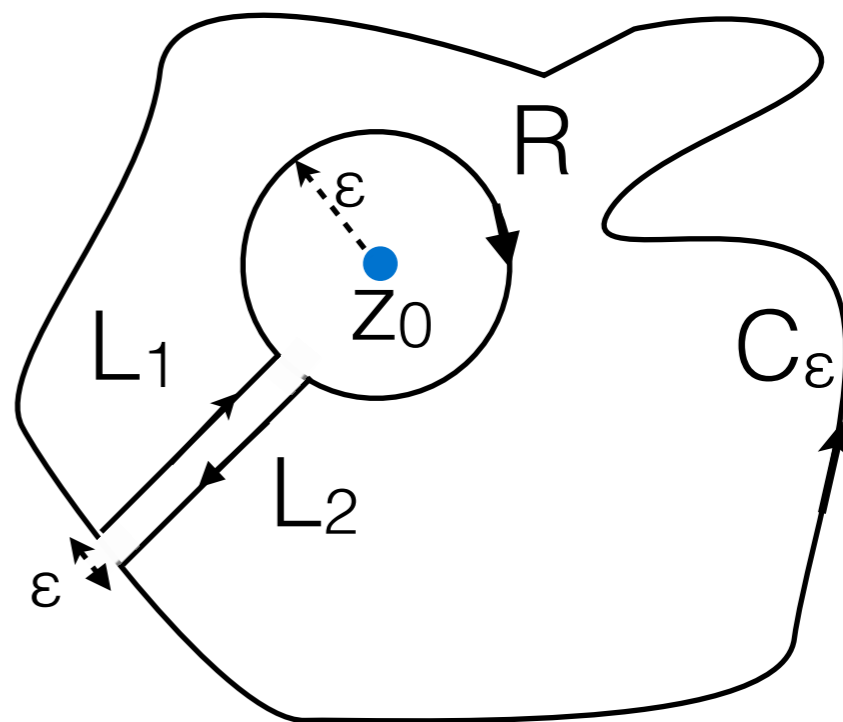

$$C' = C_\epsilon + L_1 + L_2 + R$$

$$0 = \oint_{C'} = \lim_{\epsilon \rightarrow 0} \left[\int_{L_1} + \int_{L_2} + \int_R + \int_{C_\epsilon} \right] = \lim_{\epsilon \rightarrow 0} \int_R + \int_{C_\epsilon}$$

$$\int_R \frac{f(z) dz}{z - z_0} = f(z_0) \int_R \frac{dz}{z - z_0} + \int_R \frac{f(z) - f(z_0)}{z - z_0} dz$$

$$\epsilon \rightarrow 0: \quad -2\pi i \quad O(\epsilon) \rightarrow 0$$

$$z - z_0 = \epsilon e^{i\phi}$$

$$-2\pi i f(z_0) + \int_C = 0$$

(very) useful formula

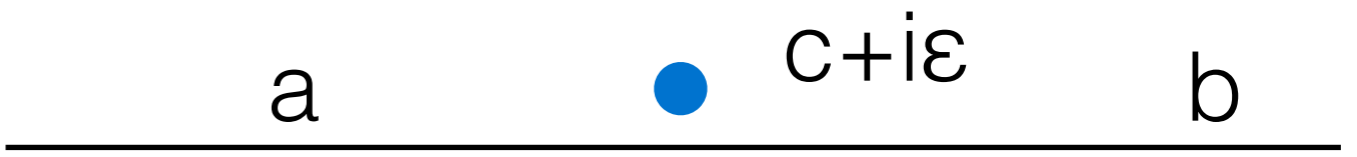
$$I = \int_a^b dx \frac{f(x)}{x - c - i\epsilon}$$

The diagram shows a horizontal line representing the real axis. Three points are marked on the line: 'a' on the left, 'c+iε' in the middle, and 'b' on the right. A blue dot is placed above the line at the position of 'c+iε'.

$$\frac{1}{x - c - i\epsilon} = \frac{x - c + i\epsilon}{(x - c)^2 + \epsilon^2}$$

$$\frac{1}{x - c - i\epsilon} = \frac{x - c + i\epsilon}{(x - c)^2 + \epsilon^2} = P.V. \frac{1}{x - c} + \frac{i\epsilon}{(x - c)^2 + \epsilon^2}$$

$$I = P.V.I + i\pi f(c)$$

Examples

Derivatives: $f(z)g(z)$

of elementary functions (may) have singularities

Integrals:

$$\int_{\gamma} dz \quad \int_{\gamma} z^n dz$$

γ = unit circle

$$\int_{\gamma} \frac{dz}{z} \quad \int_{\gamma'} \frac{dz}{z}$$

γ' = unit square

$$\int_{\gamma} \frac{dz}{z^2}$$

Series Expansion:

Series expansion approximates the function near a point.

Complex functions are determined by their singularities and series expansion will also “probe” their singularity structure.

Cauchy formula establishes existence of series representation e

Holomorphic functions are “very smooth”, e.g. existence of 1st derivative implies existence of infinite number of derivatives. This is not true for real functions, e.g.

$$f(x) = \begin{cases} x^2 & \text{for } x \geq 0 \\ -x^2 & \text{for } x < 0 \end{cases} \quad f'(x) = 2|x| \quad \text{so } f'(0) = 0 \text{ but } f''(0) \text{ does not exist}$$

$$f(x) = \begin{cases} e^{-\frac{1}{x^2}} & \text{for } x \neq 0 \\ 0 & \text{for } x = 0 \end{cases} \quad \text{all derivatives vanish at } x=0, f^{(k)}(0) = 0, \text{ and the resulting (trivial) Taylor series does not reproduce the function}$$

Hadamard's formula: The sum of powers $\sum a_n z^n$ defines a holomorphic function inside the circle of convergence R given by

$$\frac{1}{R} = \overline{\lim}_{n \rightarrow \infty} |a_n|^{1/n}$$

If $f(z)$ is holomorphic in G , $a \in G$ and C is a cycle:

$$f(z) = \frac{1}{2\pi i} \oint \frac{f(z') dz'}{z' - z} = \frac{1}{2\pi i} \oint \frac{f(z')}{z' - a} \frac{1}{1 - \frac{z-a}{z'-a}} dz'$$

for $|z'-a| > |z-a|$ we have:

$$f(z) = \frac{1}{2\pi i} \oint \frac{f(z')}{z' - a} \left[1 + \frac{z-a}{z'-a} + \frac{(z-a)^2}{(z'-a)^2} + \dots \right]$$

or integrating each term :

$$f(z) = f(a) + f'(a)(z-a) + \frac{1}{2!} f''(a)(z-a)^2 + \dots$$

this is the Taylor series

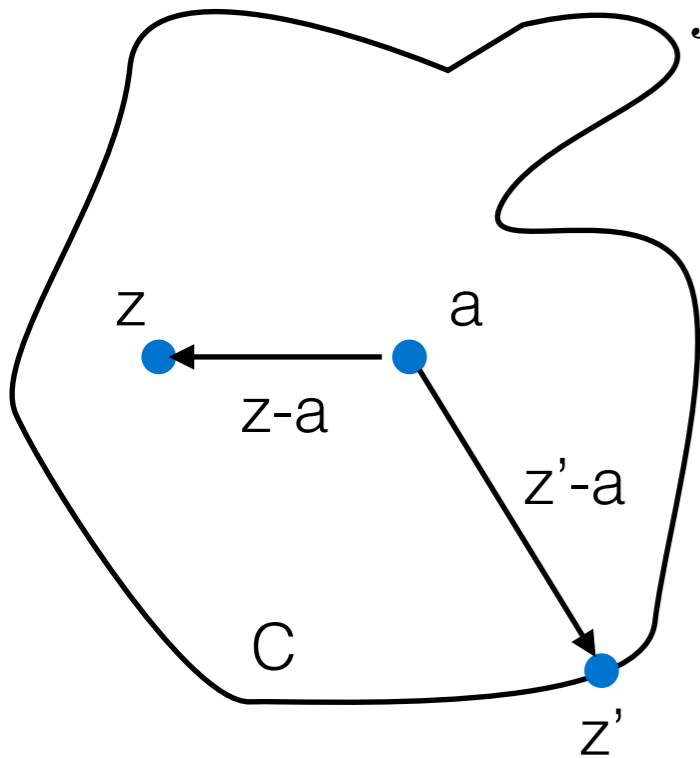

If $f(z)$ is holomorphic between two circles C_1 and C_2 and z is a point inside the ring, and a is a point inside the small circle C_1 then

$$f(z) = \frac{1}{2\pi i} \left(\oint_{C_1} \frac{f(z') dz'}{z' - z} - \oint_{C_2} \frac{f(z') dz'}{z' - z} \right)$$

the following expansions are convergent on C_2 and C_1 respectively

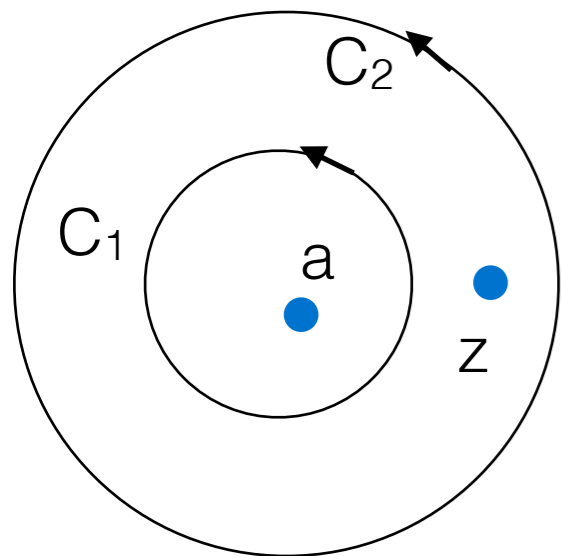

$$\begin{aligned} \frac{1}{z' - z} &= \frac{1}{z' - a} \left[1 + \frac{z - a}{z' - a} + \dots \right] \quad \text{on } C_2 \\ &= -\frac{1}{z - a} \left[1 + \frac{z' - a}{z - a} + \dots \right] \quad \text{on } C_1 \end{aligned}$$

we have:

$$f(z) = \sum_{\nu=-\infty}^{\infty} A_{\nu} (z - a)^{\nu} = \dots - \frac{A_{-2}}{(z - a)^2} + \frac{A_{-1}}{z - a} + A_0 + A_1(z - a) + A_2(z - a)^2 + \dots$$

$$A_{\nu} = \frac{1}{2\pi i} \oint_{C_2} \frac{f(z') dz'}{(z' - a)^{\nu+1}} \quad \nu \geq 0 \quad A_n = \frac{f^{(n)}(a)}{n!}, \quad (n = \nu \geq 0)$$

$$A_{\nu} = \frac{1}{2\pi i} \oint_{C_1} \frac{f(z') dz'}{(z' - a)^{\nu+1}} \quad \nu < 0$$

This is Laurent series

Classification of singularities ; What happens at a ?

Assume radius of C_1 is 0, i.e. $f(z)$ is holomorphic in $C_2 - \{a\}$ called “deleted neighborhood” of a

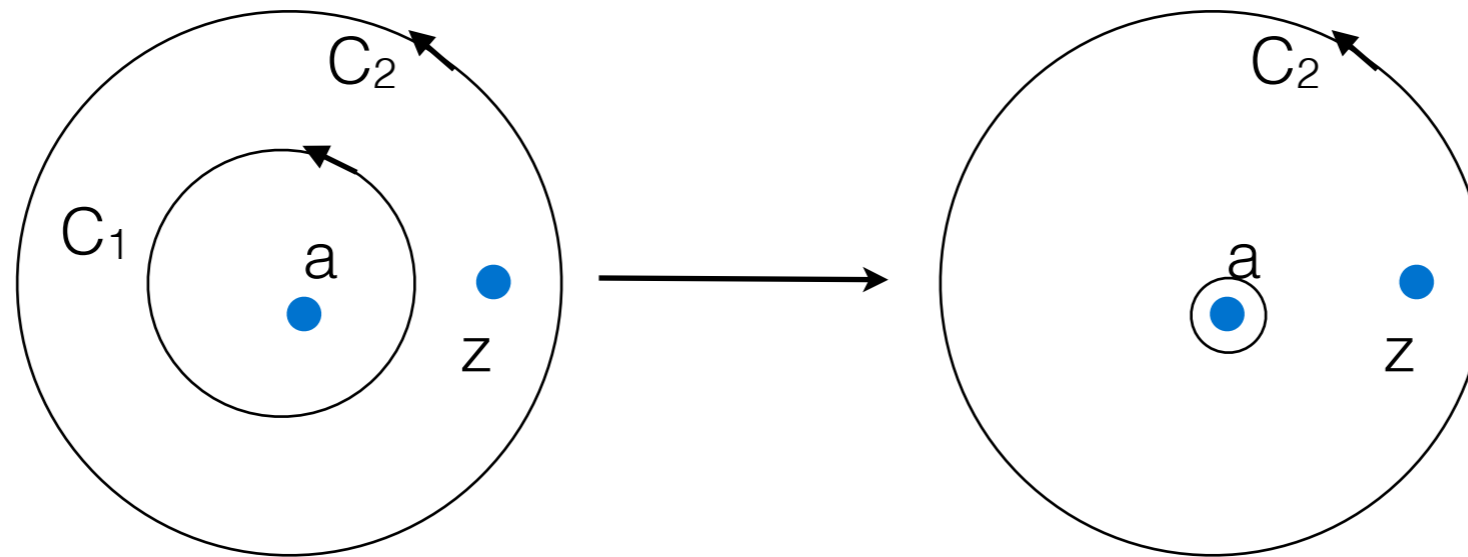

$$f(z) = \sum_{\nu=-\infty}^{\infty} A_{\nu}(z-a)^{\nu} = \frac{A_{-m}}{(z-a)^m} + \frac{A_{-m+1}}{(z-a)^{m-1}} + \dots + \sum_{n=0}^{\infty} A_n(z-a)^n$$

point a is called a pole of order m , if $m=\infty$ it is called an essential singularity, if $m=1$ it is called a simple pole (or just a pole). A_{-1} plays a special role since

$$2\pi i A_{-1} = \oint dz f(z)$$

A_{-1} is called the residue.

Examples:

$$f(z) = \frac{1}{z(z-1)}$$

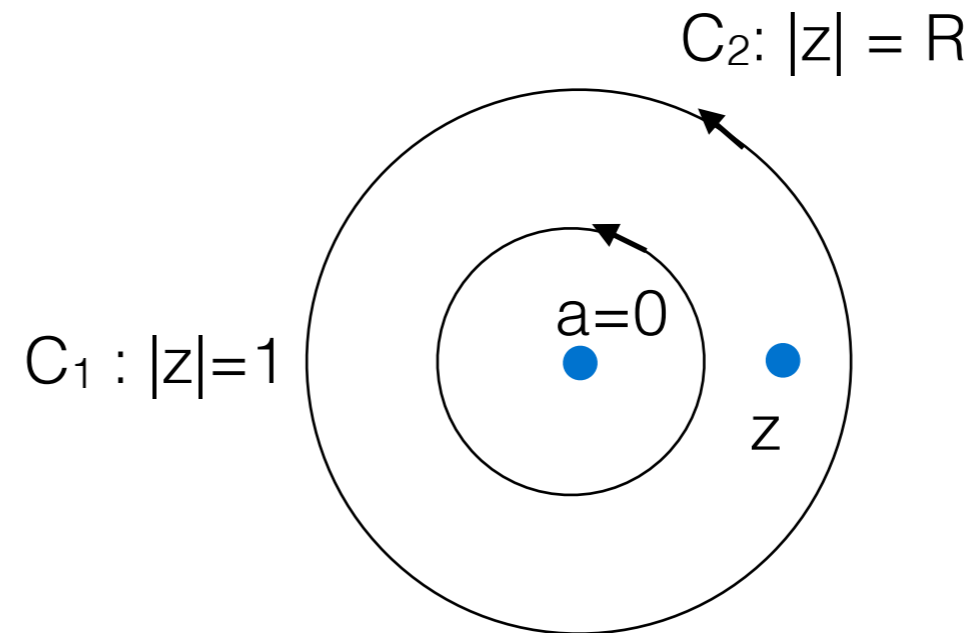

since $f(z)$ is holomorphic for $|z| > 1$, R can be chosen as large as one pleases. This implies A_n must be 0 for all $n > 0$ (otherwise $\sum A_n z^n$ would diverge for large $|z| = R$, contrary to being holomorphic)

For $|z| > 1$ Laurent series is

$$f(z) = \frac{1}{z(z-1)} = \frac{1}{z} \left[\frac{1}{z} \frac{1}{1 - \frac{1}{z}} \right] = \frac{1}{z^2} + \frac{1}{z^3} \dots$$

$a=0$ is NOT essential singularity because G is not a “deleted neighborhood” (radius of C_1 is finite)

Example:

$$f(z) = \frac{1}{z(z-1)}$$

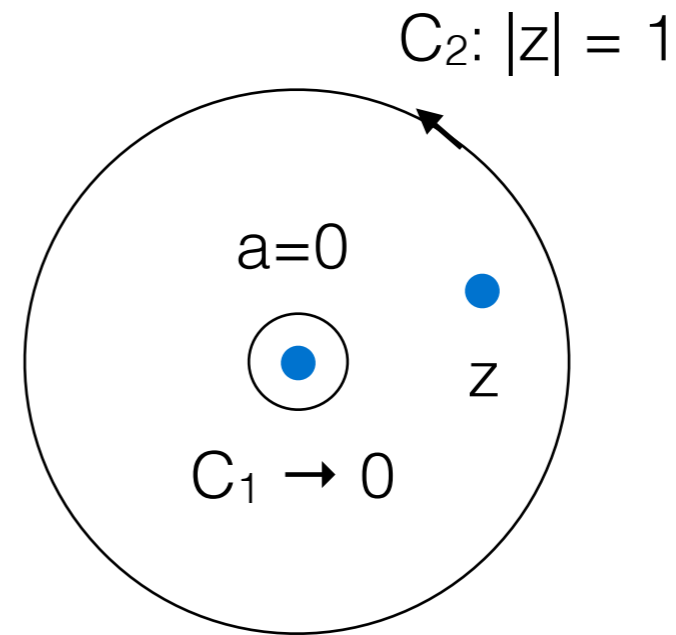

For $0 < |z| < 1$ G = “deleted neighborhood” of $a=0$ and the Laurent series is

$$f(z) = \frac{1}{z(z-1)} = -\frac{1}{z} (1 + z + z^2 + \dots) = -\frac{1}{z} - 1 - z - z^2 \dots$$

this shows (as expected) that $a=0$ is a simple pole with residue $A_{-1} = -1$

Application of

$$2\pi i A_{-1} = \oint dz f(z)$$

This is likely the most common used consequence of complex calculus, since it can be also applied to compute real integrals

Suppose you want to compute $\int_{-\infty}^{\infty} dp \frac{e^{irp}}{p^2 + m^2}$ with $m, r > 0$

consider an integral of $f(z)$ over a contour C $f(z) = \frac{e^{irz}}{z^2 + m^2}$

$f(z = Re^{i\phi}$ with $R \rightarrow \infty$) $\rightarrow 0$ (very fast)

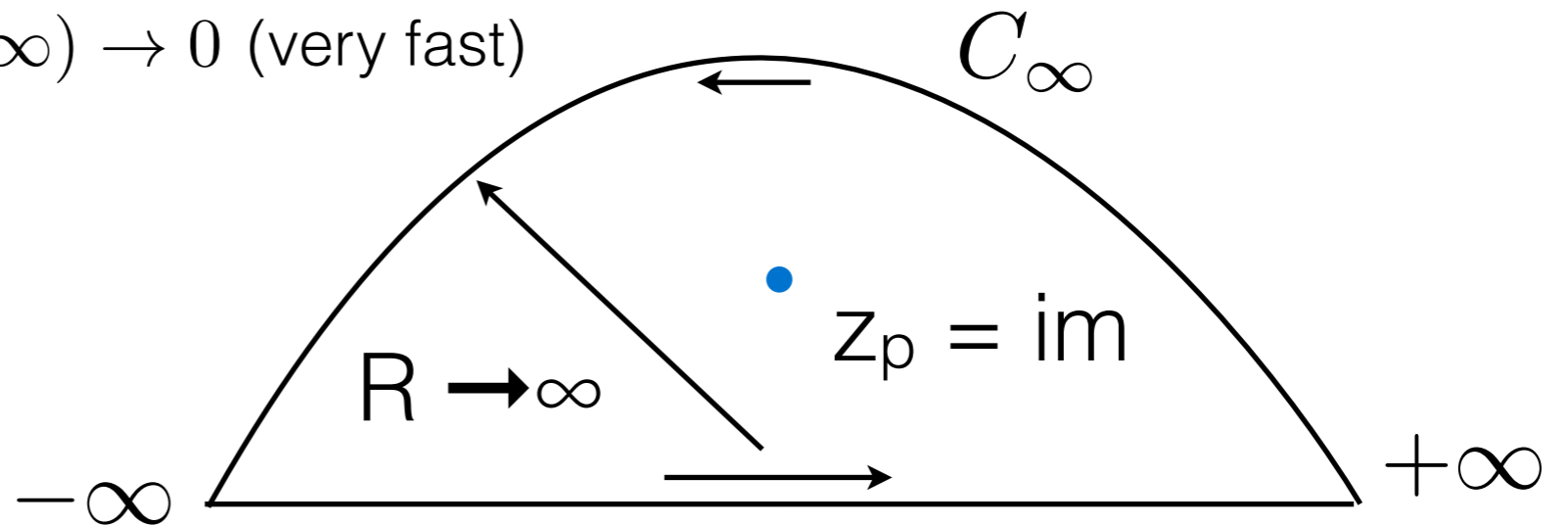

$$\oint dz f(z) = \int_{-\infty}^{\infty} dx f(x) + \int_{C_\infty} f(z) dz \rightarrow \int_{-\infty}^{\infty} dx f(x)$$

$$f(z \sim z_p) = \frac{e^{irz}}{z^2 + m^2} = \frac{e^{irz}}{(z + im)(z - im)} \sim \frac{e^{-rm}}{2im} \frac{1}{z - z_p} = A_{-1}$$

$$\int_{-\infty}^{\infty} dx \frac{e^{irx}}{x^2 + m^2} = \frac{\pi}{m} e^{-rm}$$

Which branch cut to use

Examples to consider

$$\int_{-1}^1 dx \frac{1}{\sqrt{1-x^2}}$$

$$\int_1^{\infty} dx \frac{1}{x\sqrt{x^2-1}}$$

Dispersion relations

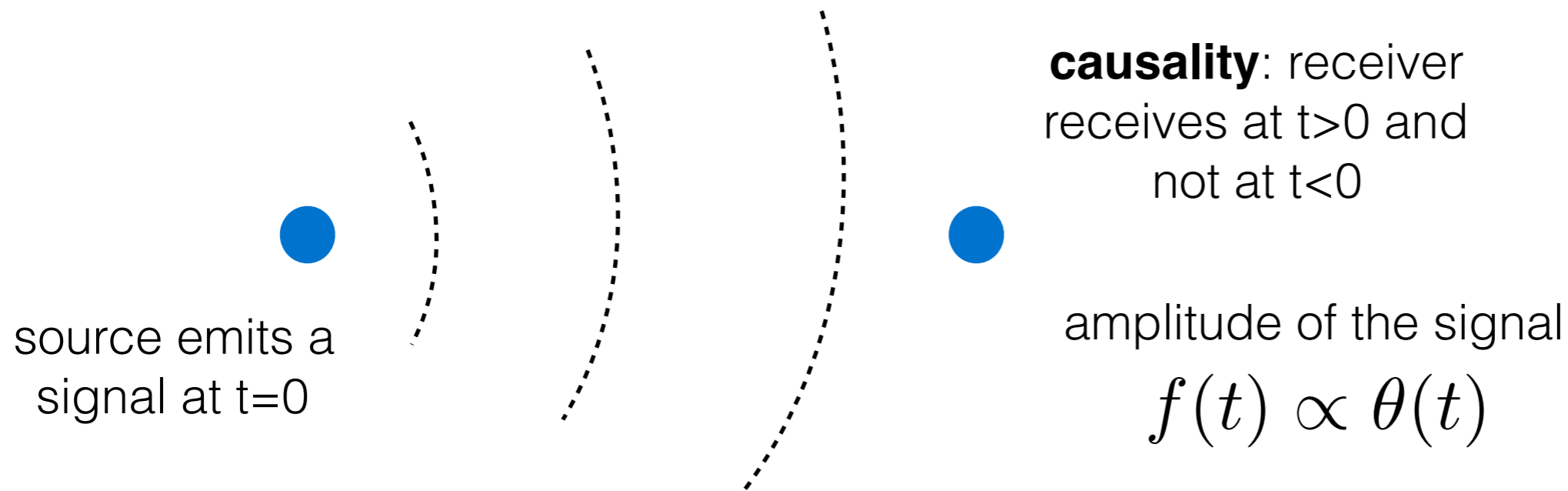

consider the Fourier transform ($E \rightarrow$ energy)

$$f(E) \equiv \int dt e^{iEt} f(t)$$

and extend definition to complex plane $E \rightarrow z$,
then $f(z)$ is holomorphic for $\text{Im } E > 0$

The idea is to determine all singularities of $f(E)$. Once this is done one can reconstruct $f(E)$ outside the region of singularities.

Suppose $f(E)$ was also analytical for $\text{Im } E \leq 0$ and $f(\infty) \rightarrow 0$

Then $f(E) = \text{constant} !$

($f(E) = \sum_n f_n E^n$ and infinite radius of convergence implies $f_1, f_2, \dots = 0$)

Singularities of $f(E)$ in the complex E -plane

$\text{Im } E > 0$ amplitudes
holomorphic

$E + i\epsilon$

$$f_{\text{physical}}(E) = \lim_{\epsilon \rightarrow 0} f(E + i\epsilon)$$



$\text{Im } E = 0$

$E = -|E_b|$

$E = 0$

$\text{Im } E = 0, \text{Re } E < 0$
amplitudes have
singularities
(bound states =
poles)

no scattering for
 $\text{Re } E < 0$, at $E=0$
change in physics
→ branch point

Reconstruction of amplitudes from its singularities : dispersion relations

Example (1)



$$f(E) = \frac{a_1}{E - E_1} + \frac{a_2}{E - E_2} + \sum_{n=0} b_n E^n$$

Need to specify behavior at ∞

1. $f(\infty) \rightarrow \text{const}$ $b_n = 0, n > 0$
2. $f(\infty) \rightarrow 1/s$ $b_n = 0$
3. $f(\infty) \rightarrow 1/s^2$ $b_n = 0, a_1 = -a_2$

Dis. $f(E) = f(E + i\epsilon) - f(E - i\epsilon) = 2i\sqrt{E}$ for $E > 0$
in addition $f(0)=1$, and is analytical everywhere else what
is $f(E)$? Can $f(\infty)$ be a constant?

$$f(E) = \frac{1}{2\pi i} \oint dz \frac{f(z)}{z - E}$$

$$= \frac{1}{2\pi i} \int_{-\infty}^0 dE' \frac{f(E' - i\epsilon)}{E' - i\epsilon - E} + \int_0^{\infty} dE' \frac{f(E' + i\epsilon)}{E' + i\epsilon - E} + \int_R \dots$$

$$= \frac{1}{2\pi i} \int_0^{\infty} dE' \frac{2i\sqrt{E'}}{E' - E} + \frac{1}{2\pi} \int_R d\phi f(Re^{i\phi})$$

const.

$$f(E) = -\sqrt{-E} + 1$$

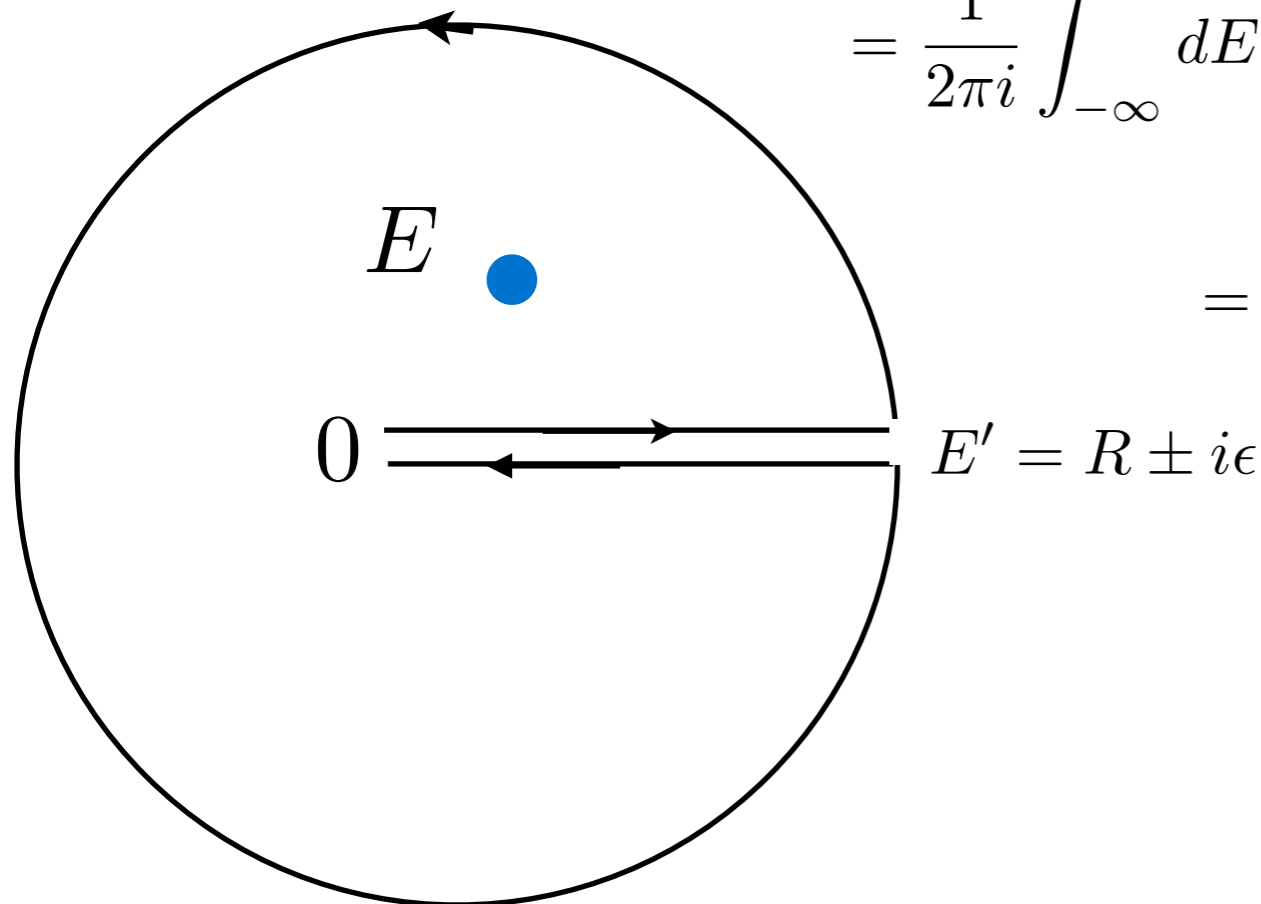

in scattering, Dis $f(E)$ is related to observables (unitarity)
 $f(0)$ is “subtraction constant”: one trades the large- s
behavior for small- s one

Example (2)

Relativistic scattering

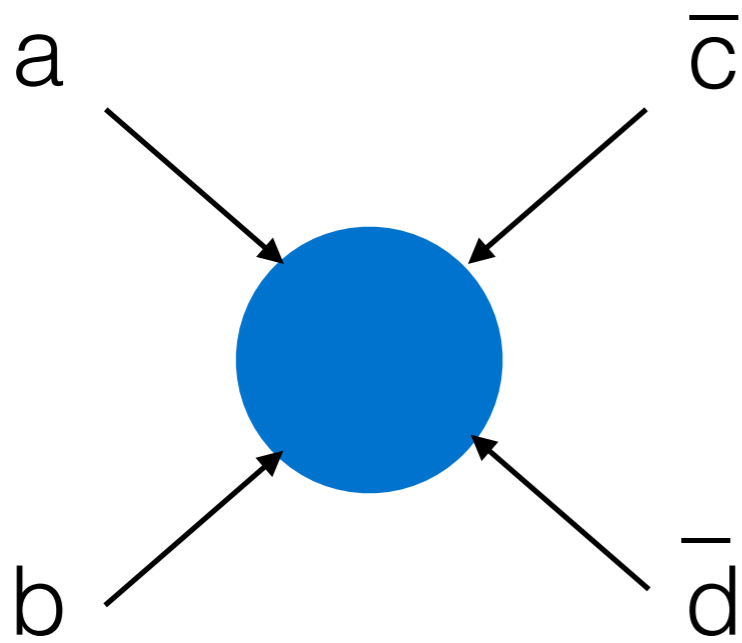

$$s = (p_a + p_b)^2$$

$$t = (p_a + p_{\bar{c}})^2 = (p_a - p_c)^2$$

$$u = (p_a + p_{\bar{d}})^2 = (p_a - p_d)^2$$

$$s + t + u = \sum_i m_i^2 = 4m^2$$

$A(s,t)$ for $s > 4m^2$ $t < 0$ describes $a + b \rightarrow c + d$

$A(s,t)$ for $s > 0$ $t < 4m^2$ describes $a + \bar{c} \rightarrow \bar{b} + d$

$A(s,t)$ for $u > 0$ $s < 4m^2$ describes $a + \bar{d} \rightarrow \bar{b} + c$

In relativistic scattering

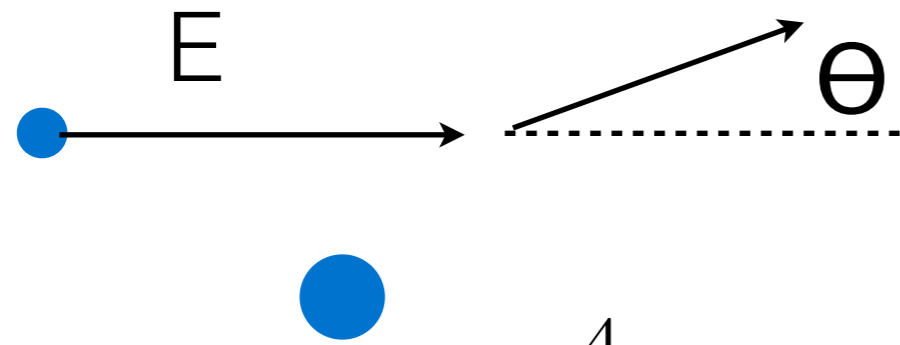

$$a + b \rightarrow c + d$$

$$s = M^2 + m^2 + 2EM$$

$$A(s, \cos \theta) = A(s, t)$$

$$s + t + u = \sum_{i=1}^4 m_i^2$$

In S-matrix theory it is assumed that a single complex function $A(s,t,u)$ describes all reactions related by crossing

similarly to s for $a + b \rightarrow c + d$, the variable u is related to energy for the reaction $a + \bar{d} \rightarrow c + \bar{b}$

since $u = \sum m^2 - s - t$ if $A(u)$ is holomorphic for $\text{Im } u > 0$ it is also holomorphic in s for $\text{Im } s < 0$

t-channel

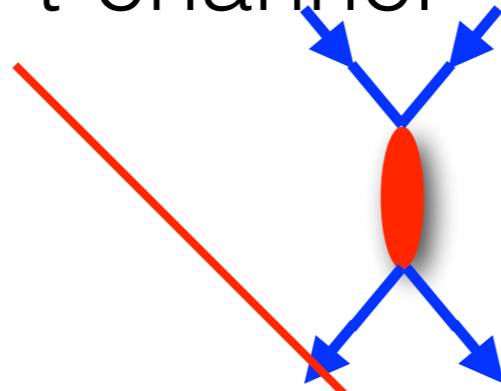

Analytical continuation:
How from knowledge of $f(s,t,u)$ in one region (e.g. t-channel) we can find it in other region (e.g. u-channel)

t

u-channel

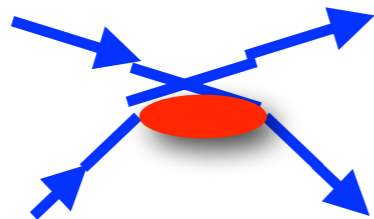

s

s-channel

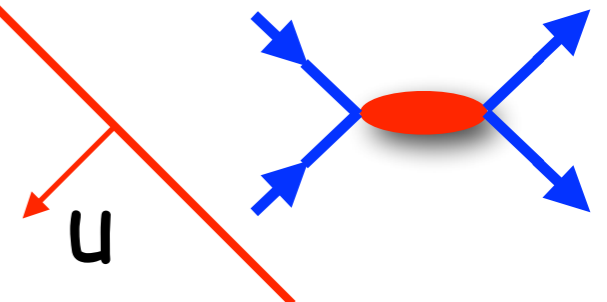

u



S. Mandelstam

Analytical continuation

For real functions it does not work

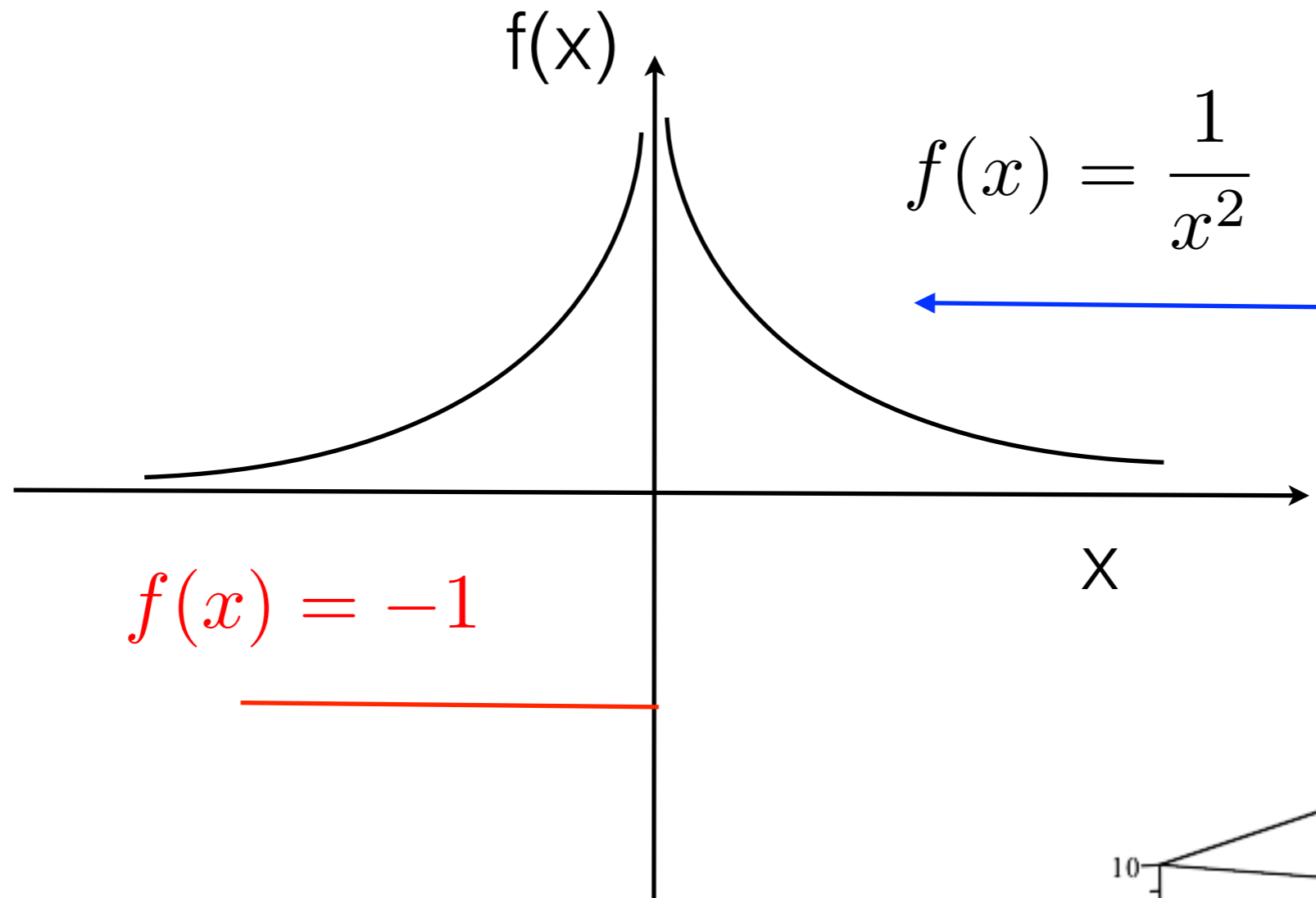

but for complex functions you can go continuously around the $z=0$ singularity and *analytically continue* from one region to another

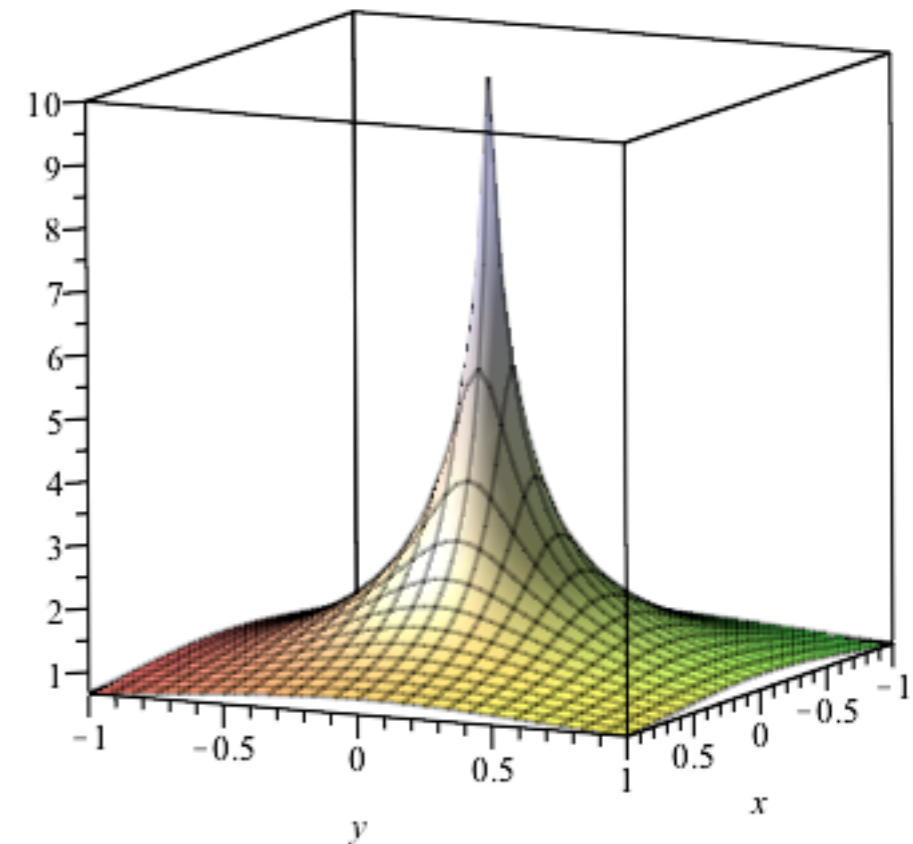

Theorem: If $f(z)$ is holomorphic on G and $f(z)=0$ on an arc A in G , then $f(z)=0$ everywhere in G

Proof: $f(z)=0$ on A implies $f'(z)=0$ on A , because we can take the limit $\Delta z \rightarrow 0$ along the arc. Thus all derivatives vanish along A . Then by Taylor expansion around some point z_0 of A , $f(z) = \sum f^{(n)}(z_0)(z-z_0)^n/n! = 0$, for z inside some circle C . Now we take another arc A' along $f(z)=0$, etc. Continuing this process everywhere in G we prove the theorem.

If $f(z)$ is holomorphic on G then $f(z)$ is uniquely defined by its values on an arc A in G .

Analytical continuation

Let $f_1(z)$ be holomorphic in G_1 and $f_2(z)$ in G_2 , G_1 and G_2 intersect on an arch A (or domain D), and $f_1 = f_2$ on A (or D) then f_1 and f_2 are analytical continuation of each other and

$$f(z) = \begin{cases} f_1(z), & z \in G_1 \\ f_2(z), & z \in G_2 \end{cases}$$

is holomorphic in the union of G_1 and G_2

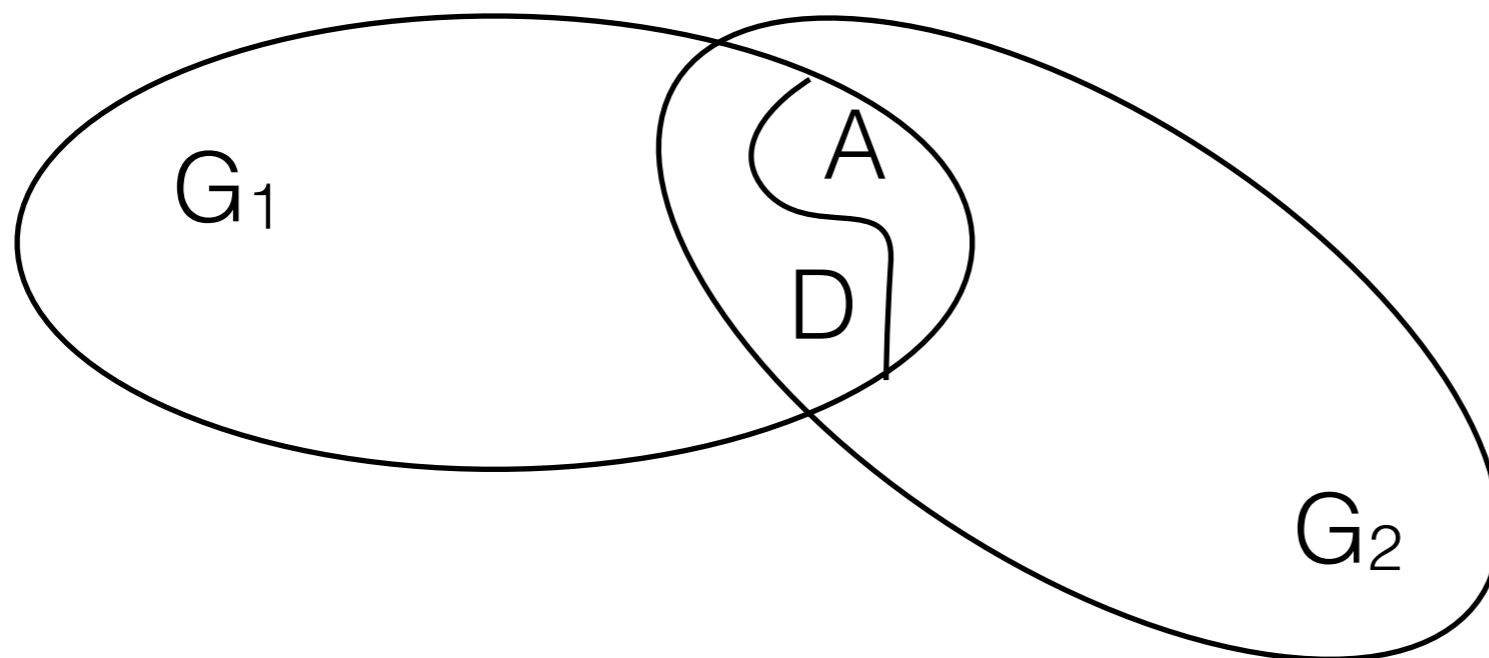

Examples:

$1 + z + z^2 + \dots$ is holomorphic in $|z| < 1$

$\int_0^\infty e^{-(1-z)t} dt$ is holomorphic in $\operatorname{Re} z < 1$

$-(1 + 1/z + 1/z^2 + \dots)$ is holomorphic in $|z| > 1$

all these functions represent $f(z) = 1/(1-z)$ in different domains, which is holomorphic everywhere except at the point $z=1$

$\Gamma(z)$ function:

$\Gamma(z+1) = z\Gamma(z)$: generalization of factorial
 $n! = n(n-1)!$ so $\Gamma(n) = (n-1)!$

$$\Gamma(z) = \int_0^{\infty} \frac{dt}{t} t^z e^{-t} \quad \Gamma(0) \sim \log 0 \quad \Gamma(-1) \sim \frac{1}{0} \quad \Gamma(-n) \sim \frac{1}{0^n}$$

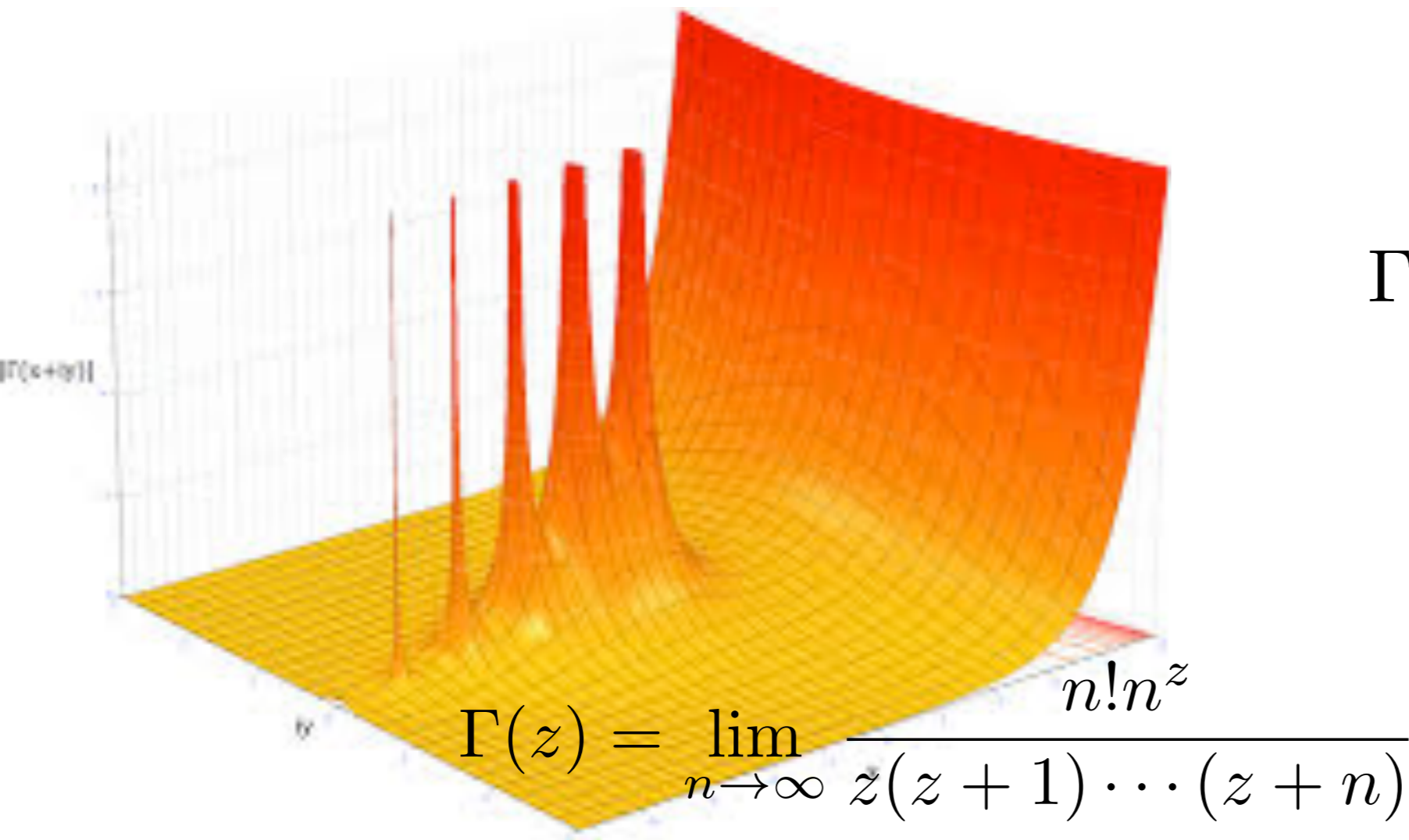

$$\Gamma(z) \sim \frac{(-1)^n}{n!} \frac{1}{z+n}$$

for $z \sim -n$

Why would you ever care about the Γ function (?)

Infinite number of poles

If QCD were confined it would have ∞ of poles !

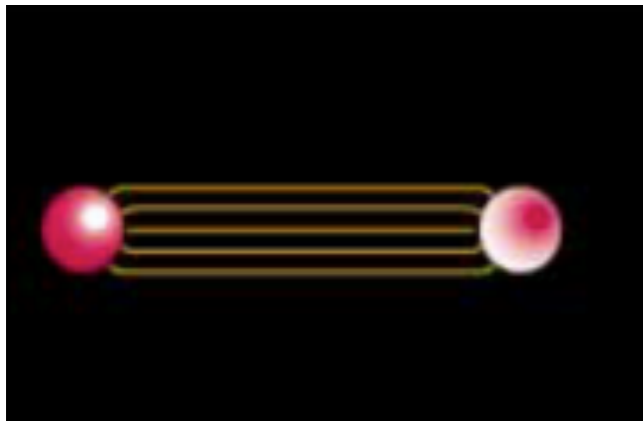

$$J(M^2) = \frac{1}{2\pi\sigma} M^2 = \alpha' M^2$$

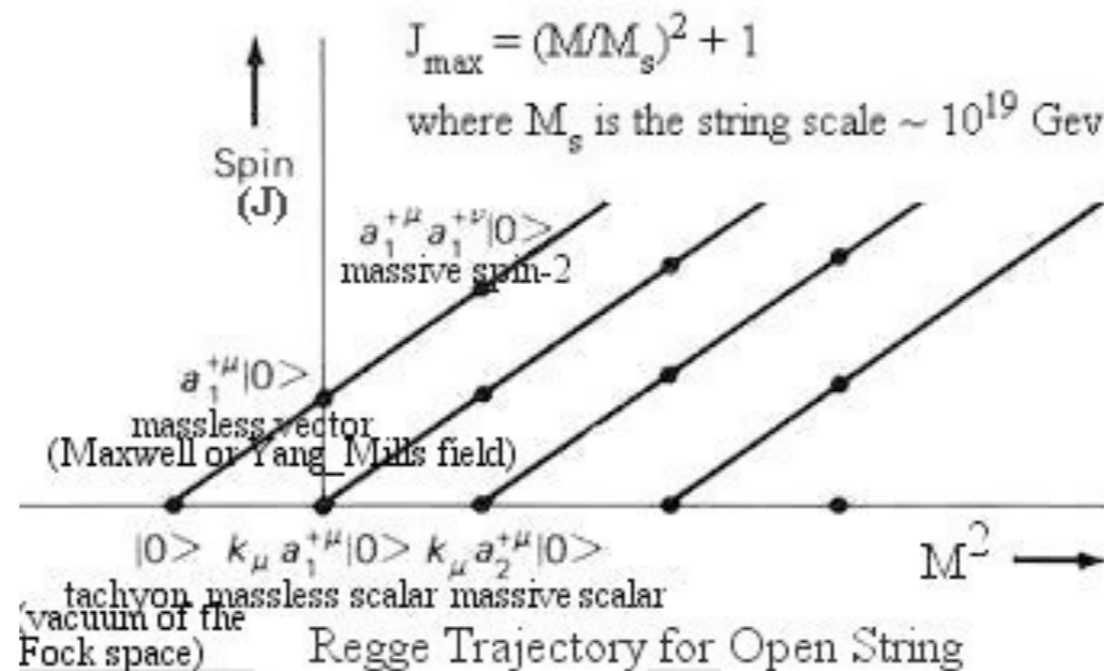
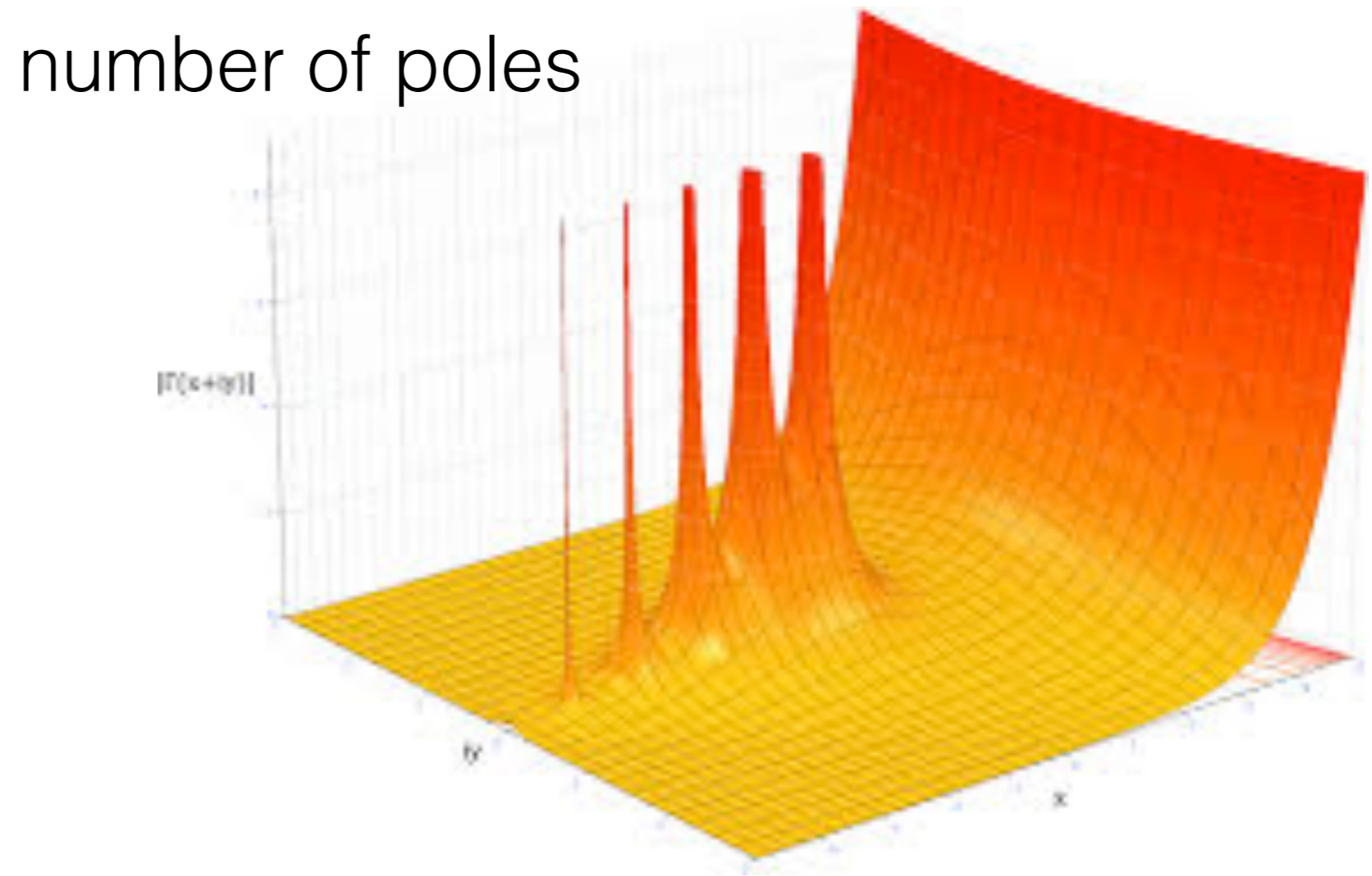



relativistic h.o.



string of relativistic oscillators

QCD, loop representation, large- N_c , AdS/CFT, ...

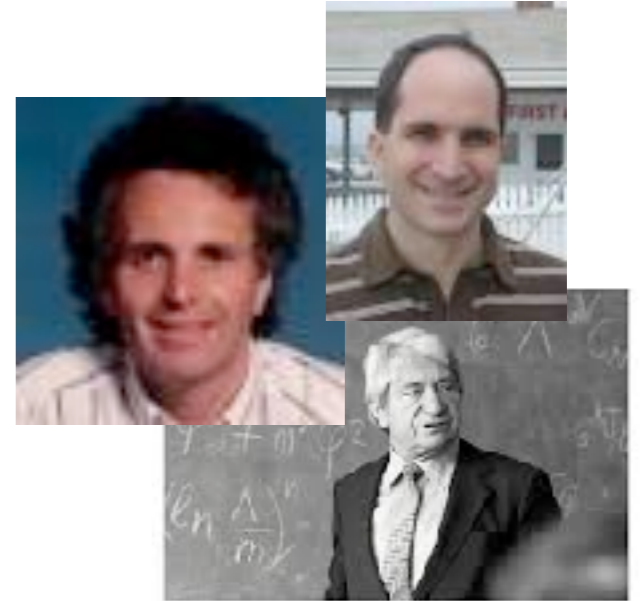

$\omega \rightarrow 3\pi$

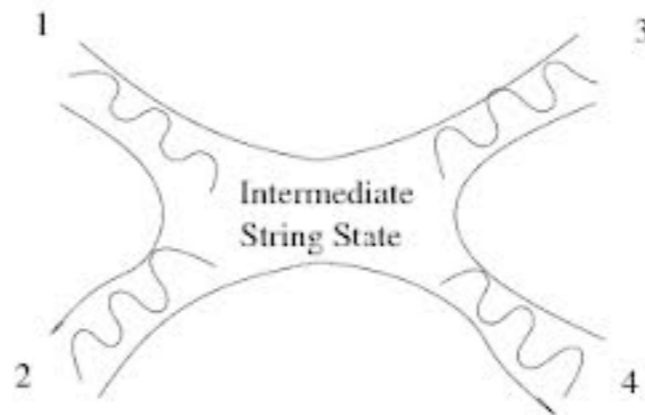

string revolution



$$A(s, t) = \frac{\Gamma(-J(s))\Gamma(-J(t))}{\Gamma(-J(s) - J(t))}$$

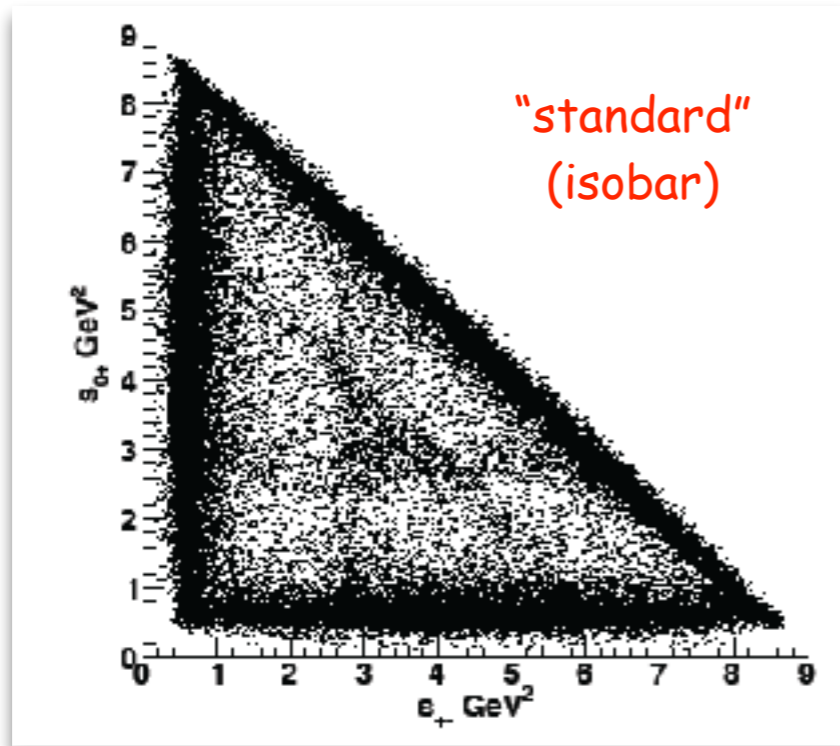

manifestation of force
- particle duality ?

$$A(s, t) = \frac{\Gamma(-J(s))\Gamma(-J(t))}{\Gamma(-J(s) - J(t))}$$

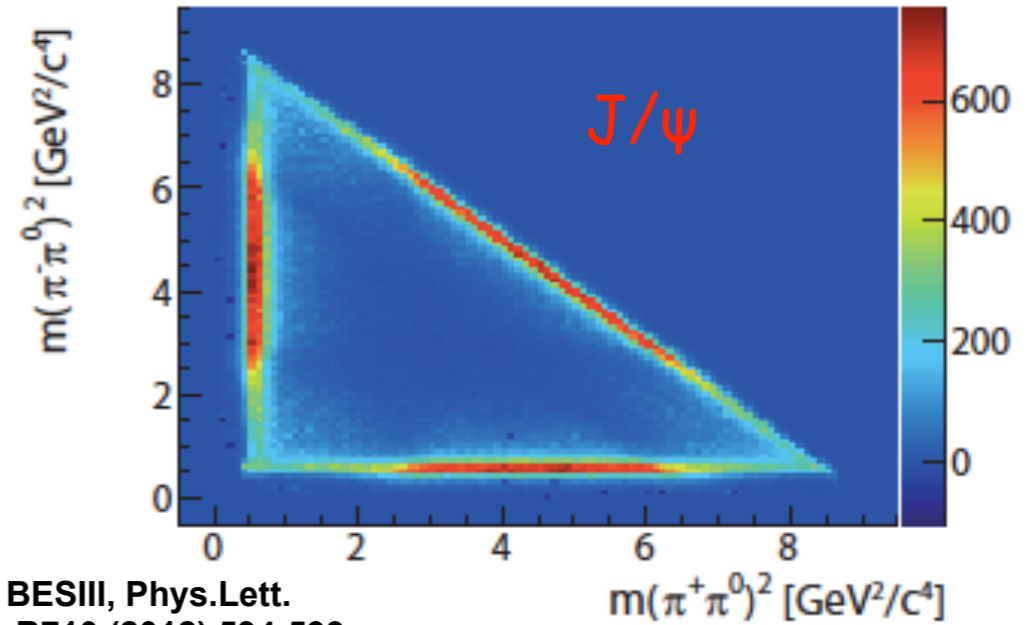

BESIII, Phys.Lett.
B710 (2012) 594-599

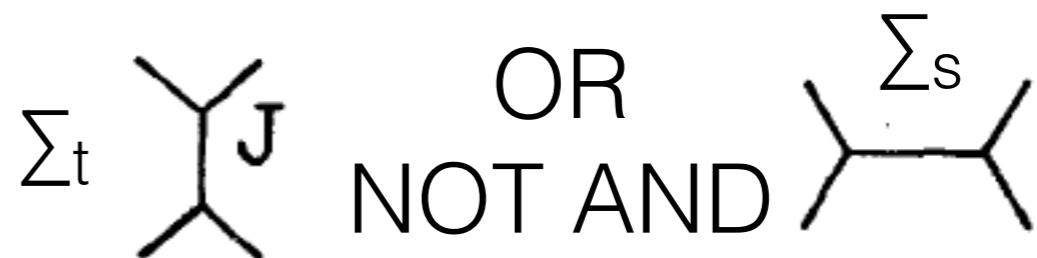
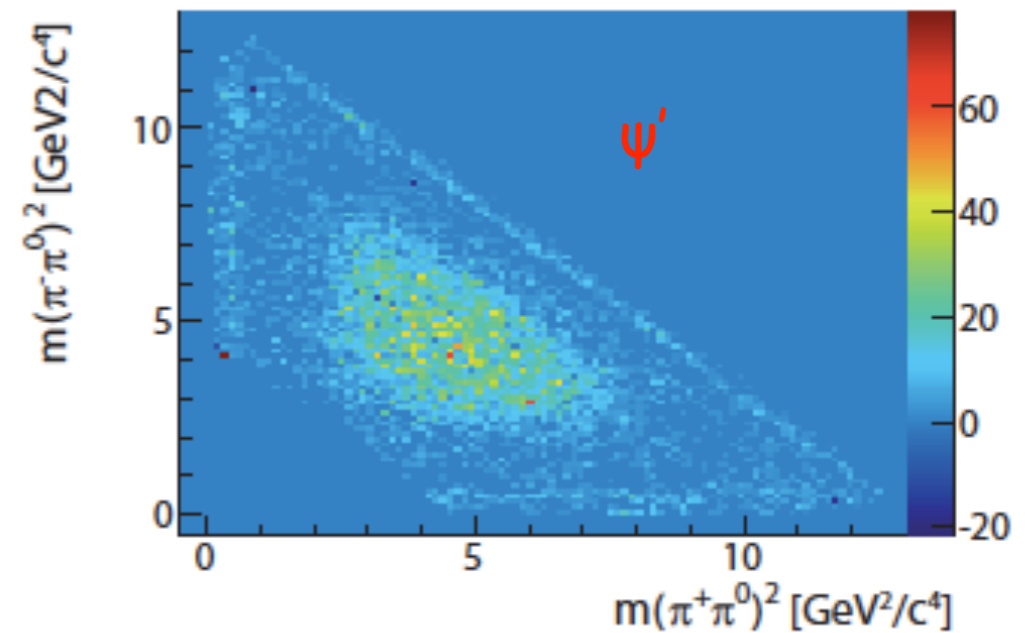

t-channel

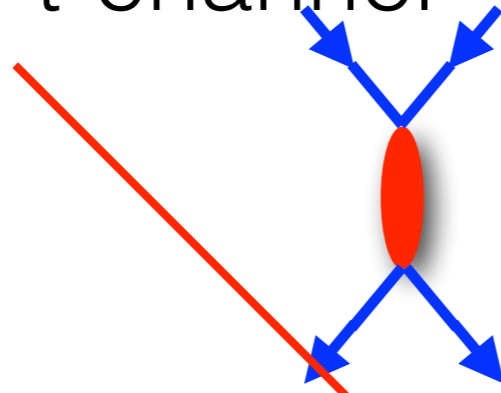

how analytical continuation happens in practice for scattering amplitudes

t

u-channel

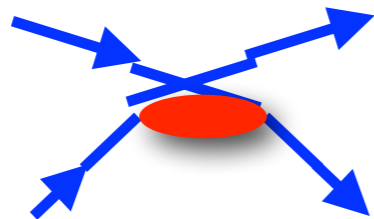

s-channel

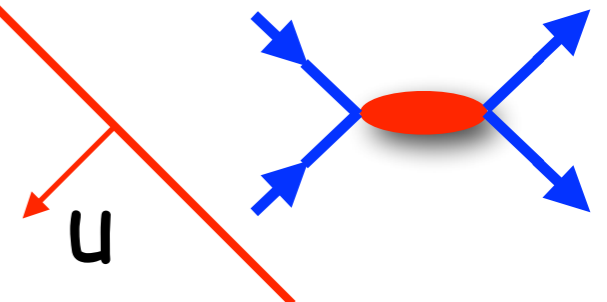

s

u



S. Mandelstam

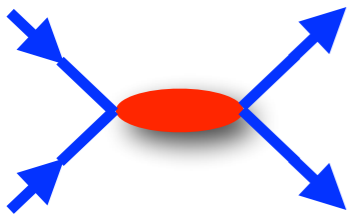

$$f(s, t) = \sum_n f_n(s) t^n$$

unitarity in s-channel Disc. $f_n(s) \neq 0$

s-channel sum
over t must
diverge to
reproduce a t-
channel
singularity in t
(and vice versa)

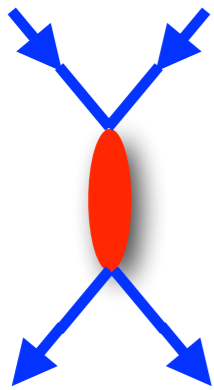

$$f(s, t) = \sum_n f'_n(t) s^n$$

unitarity in t-channel Disc. $f'_n(t) \neq 0$

sum over n in s-channel p.w. is replaced by an integral
(Mandelstam)

$$A(s, t) = \int dt_1 dt_2 K(s, t_1, t_2, t) A(s, t_1) A^*(s, t_2)$$

Continuation of integral representation $g(w) = \int_C f(z, w) dz$

what are the possibilities for $g(w)$ to be singular?

Let D be a neighborhood of the arc C and G be a domain in the w -plane, $f(z, w)$ be regular in both variables, except for a finite number of isolated singularities or branch points.

$g(w)$ can be singular at $w_0 \in G$ only if

1. $f(z, w_0)$ in z -plane has a singularity coinciding with the end points of the arc C (end-point singularity)
2. two singularities of f , $z_1(w)$ and $z_2(w)$, approach the arc C from opposite sides and pinch the arc precisely at $w=w_0$. (pinch singularity)
3. a singularity $z(w)$ tends to infinity as $w \rightarrow w_0$ deforming the contour with itself to infinity; one has to change variables to bring the point ∞ to the finite plane to see what happens.

Examples

Apparent singularities need not be there !

$$f(z) = \int_{-1}^1 \frac{dx}{x - z} \quad C = [-1, 1]$$

looks like a regular function of z in the entire plane except for the interval $z \in [-1, 1]$

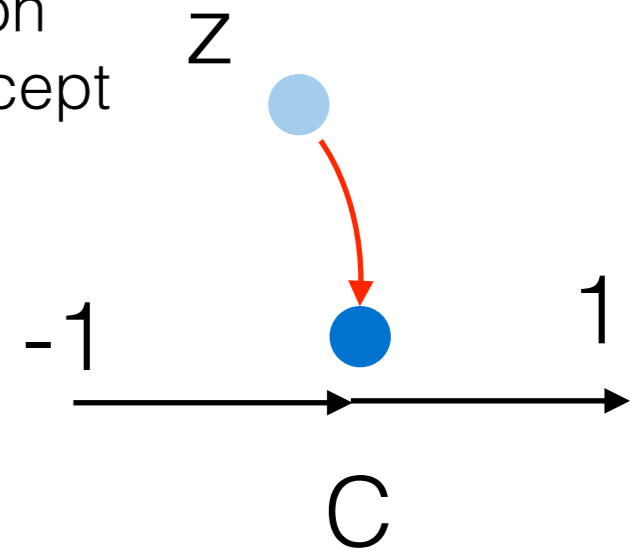
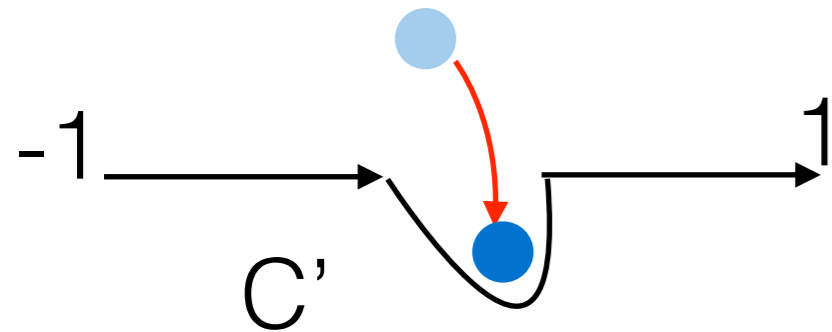

when z approaches x deforming C allows to define a function $f(z)$ which changes continuously

... however when z returns to the original point we end up with a different function value. $f(z)$ is multivalued and -1 is a branch point.

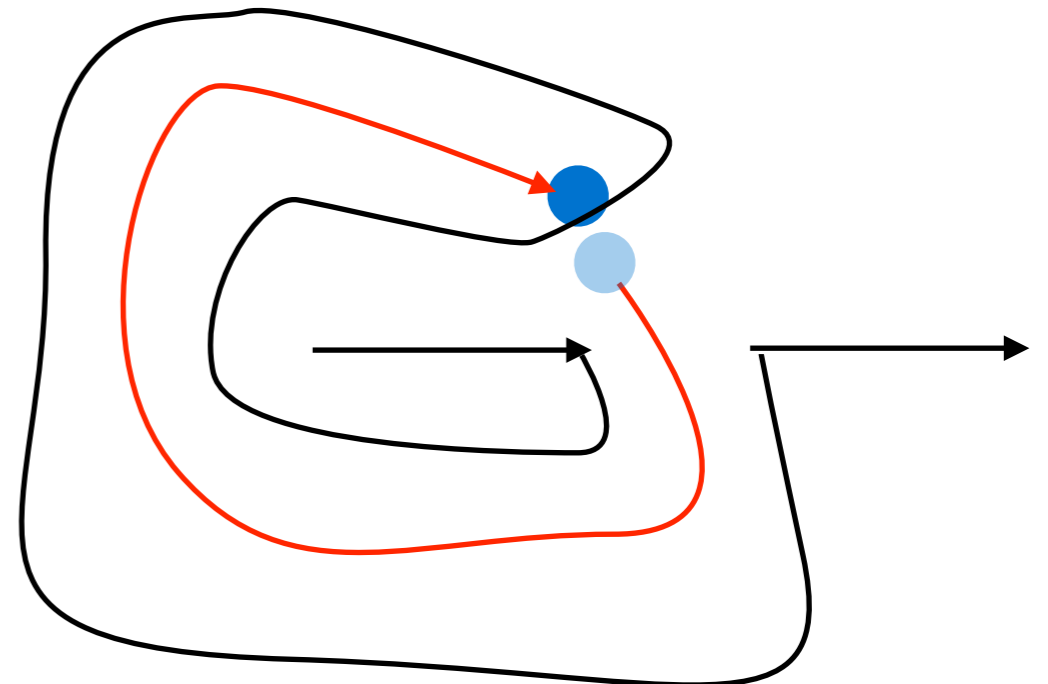
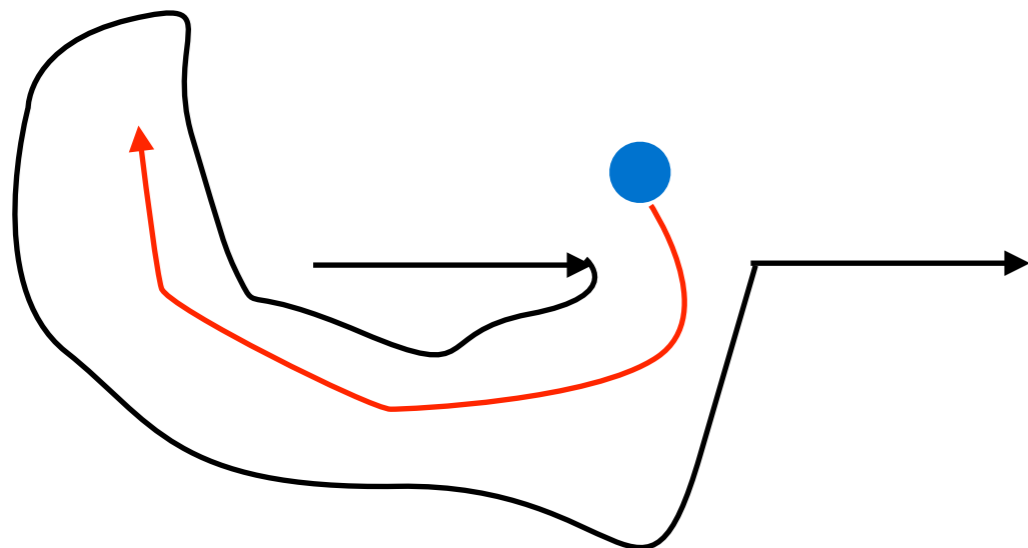

$$f(z) = \int_{-1}^1 \frac{dx}{x-z}$$

if we don't deform the contour, then $f(z)$ is analytical everywhere except on the real axis between $[-1,1]$

$$f(z) = \text{Log}(1-z) - \text{Log}(-1-z)$$

$$f(z_0 + i\epsilon) = (\log|1-z_0| + 0i) - (\log|1+z_0| - i\pi) = \log \frac{|1-z_0|}{|1+z_0|} + i\pi$$

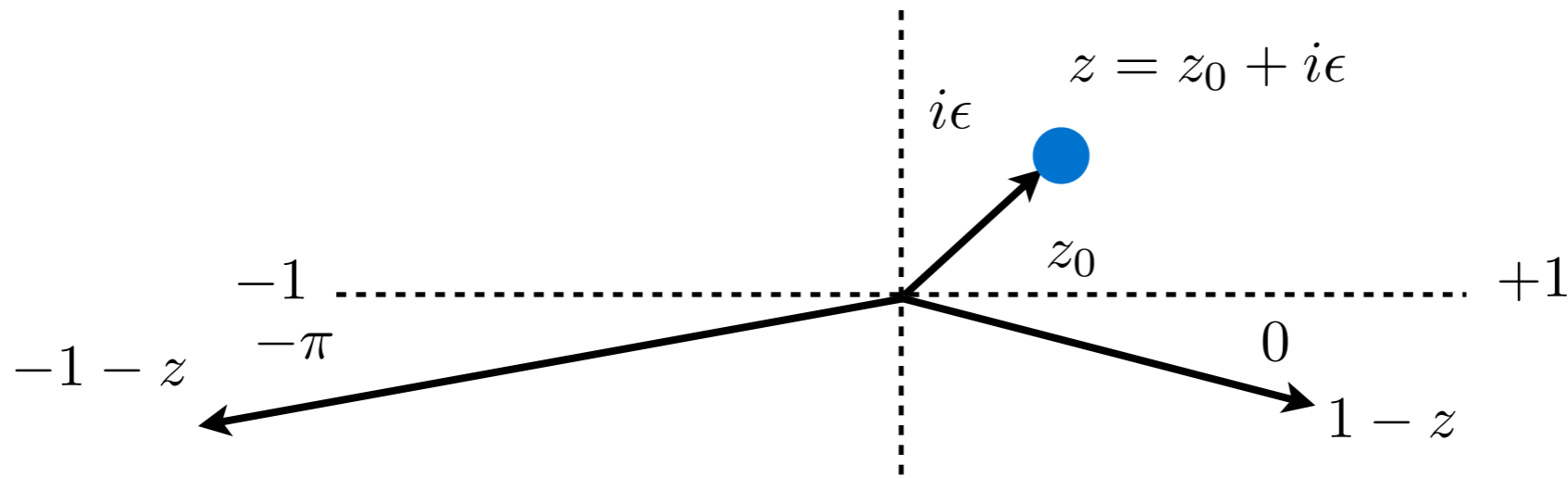

$$f(z_0 - i\epsilon) = (\log|1-z_0| + 0i) - (\log|1+z_0| + i\pi) = \log \frac{|1-z_0|}{|1+z_0|} - i\pi$$

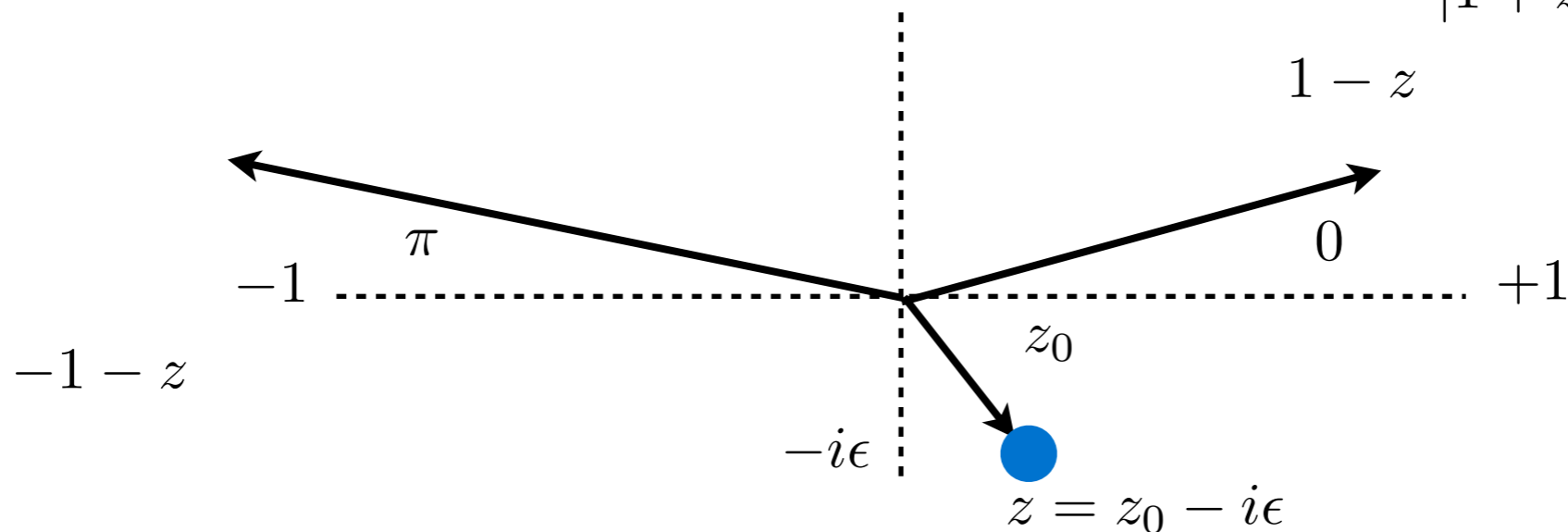

$f(z)$ jumps as z crosses the real axis, $f(z_0+i\epsilon)-f(z_0-i\epsilon) = 2\pi i$. We say $f(z)$ has a cut $[-1:1]$ and $2\pi i$ is the value of the discontinuity across the cut (happens to be constant) i.e. $f(z)$ is analytical everywhere except $[-1:1]$

how distorting contour makes $f(z)$ continuous
 e.g. take $z = 0 + i\epsilon$ and move towards $0 - i\epsilon$

$$f(z) = \int_{-1}^1 \frac{dx}{x - z}$$

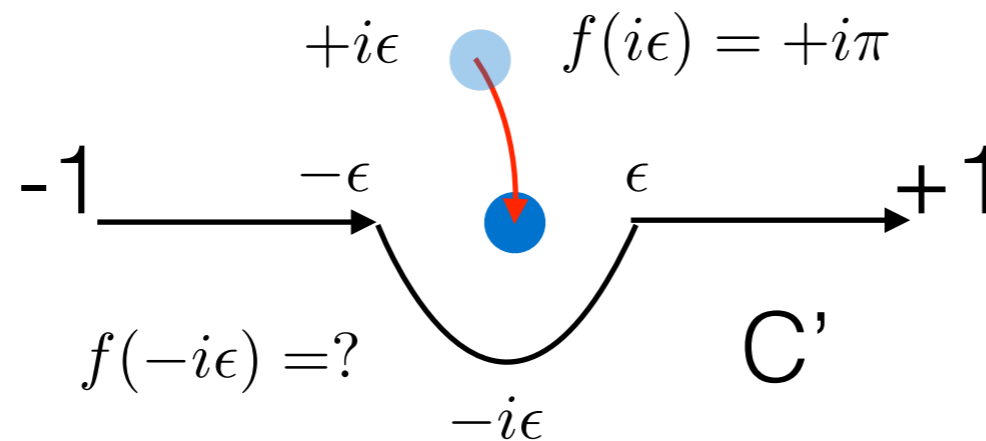

$$\begin{aligned} f(0) &= \int_{C'} \frac{dx}{x - 0} = \int_{-1}^{-\epsilon} \frac{dx}{x} + \int_{\epsilon}^1 \frac{dx}{x} + \int_{-\pi}^0 \frac{id\phi \epsilon e^{i\phi}}{\epsilon e^{i\phi}} \\ &= \log \epsilon - \log \epsilon + i\pi = i\pi \end{aligned}$$

as promised, $f(z)$ varies smoothly as z crosses the real axis (provided the contour is distorted) It is no longer discontinuous across $[-1:1]$

we can define (single-valued) $f(z)$ in a different domain, e.g with a cut $[-\infty, -1]$

$$f(z) = \int_{C'} \frac{dx}{x-z}$$

$$\int_{-1}^{-\infty} \frac{dx}{x-z} = \int_1^{\infty} \frac{dx}{x+z}$$

$$\int_{\infty}^1 \frac{dx}{x-z} = - \int_1^{\infty} \frac{dx}{x-z}$$

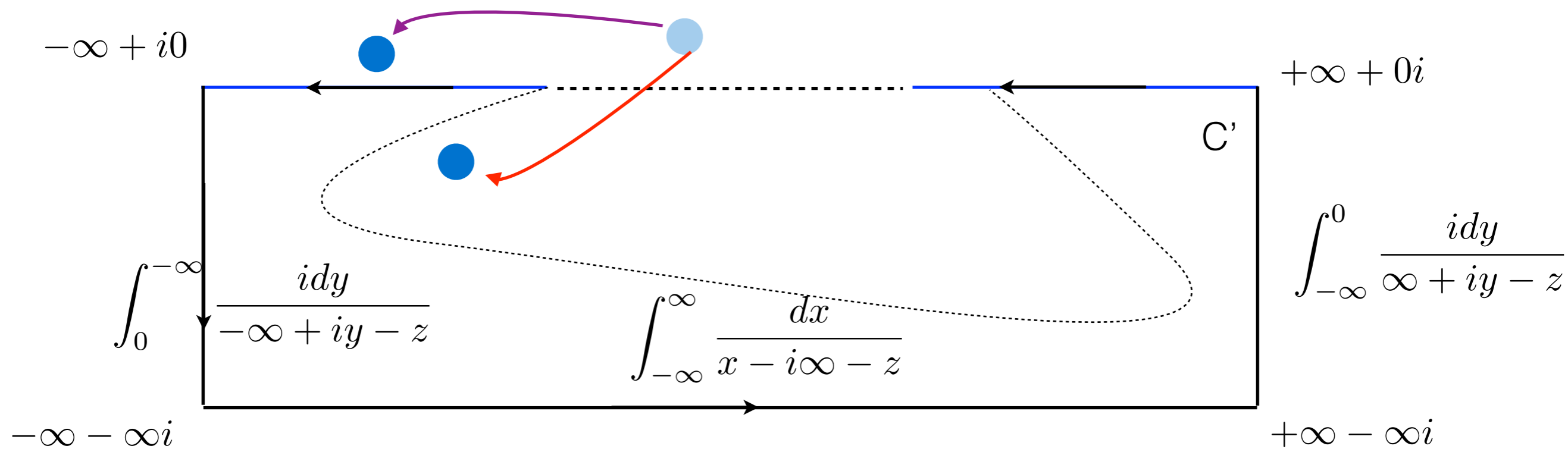

$$f(z) = -2z \int_1^{\infty} \frac{dx}{x^2 - z^2}$$

$$f(z + i\epsilon) - f(z - i\epsilon) = -2\pi i \quad \text{for } z < -1 \text{ or } z > 1$$

$$f(z) = -\log(1+z) - \log(-1-z) \quad \text{everywhere else}$$

and it is the same function as the one which had the $[-1:1]$ cut outside the real axis

Note that $z = \pm 1$ are singular (branch) points (end-point singularities)

Example: pinch singularity

$$k = (k^0, \mathbf{k})$$

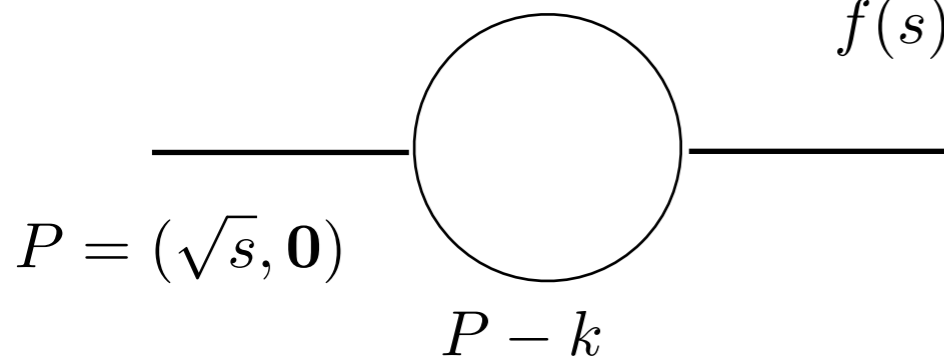

$$f(s) = i \int \frac{d^4 k}{(2\pi)^3} \frac{1}{(k^0)^2 - \mathbf{k}^2 - m^2 + i\epsilon} \frac{1}{(\sqrt{s} - k^0)^2 - \mathbf{k}^2 - m^2 + i\epsilon}$$

as $\epsilon \rightarrow 0$ these two poles “pinch” the contour i.e. it cannot be deformed without crossing one of them

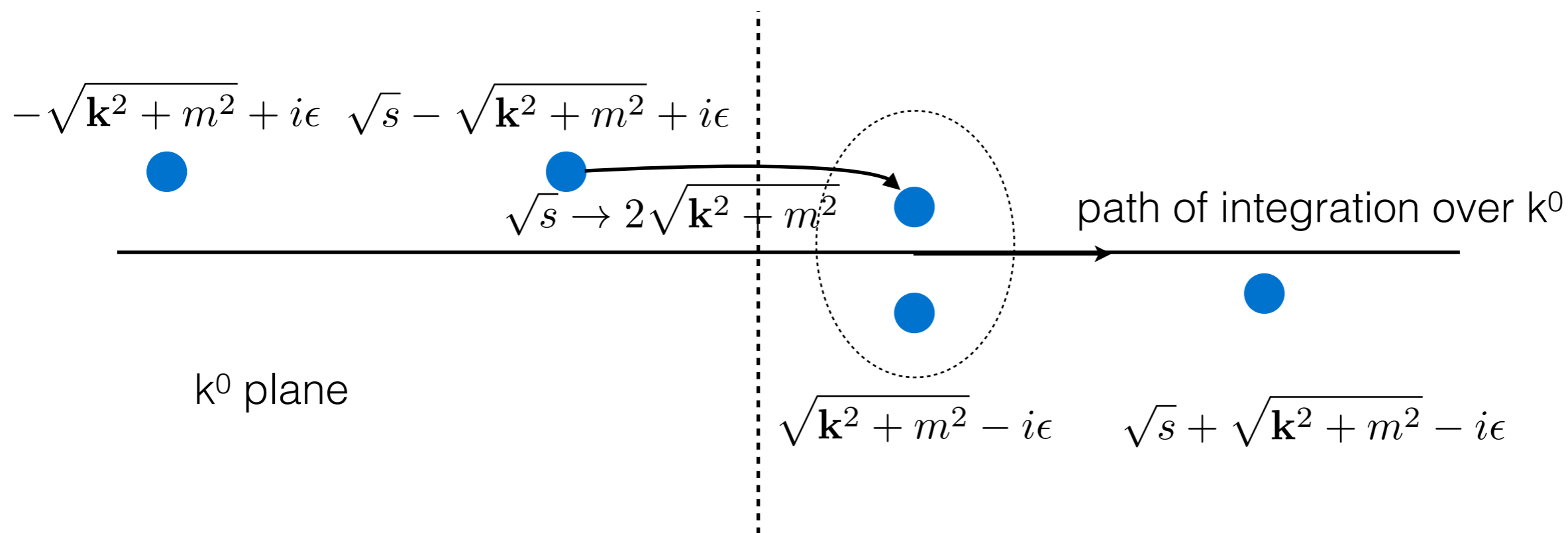

This happens for any \mathbf{k} , so we expect $f(s)$ to be singular for all $s > 4m^2$

$$f(s + i\epsilon) - f(s - i\epsilon) \propto \sqrt{1 - \frac{4m^2}{s}} \theta(s - 4m^2)$$

Hunting for a resonance $Im f_l(s) = \rho(s) f_l(s) f_l^*(s)$

$f(s)$ is a real-analytic function : $f(s^*) = f^*(s)$

$$f_l(s + i\epsilon) - f_l(s - i\epsilon) = 2i\rho(s) f_l(s + i\epsilon) f_l(s - i\epsilon)$$

1st sheet $s_1 = 3 + 0.01 i$: $f(s_1)$

1st sheet $s_2 = 3 - 0.01 i$: $f(s_2)$ $f(s_1) - f(s_2) = \text{"large"}$

$$f_l(s + i\epsilon) = \frac{f_l(s - i\epsilon)}{1 - 2i\rho(s) f_l(s - i\epsilon)}$$
$$f^{2nd}(s) = \frac{f_l(s)}{1 - 2i\rho(s) f_l(s)} \quad (*)$$

use (*) to define analytical continuation of f to the second sheet

1st sheet $s_1 = 3 + 0.01 i$: $f(s_1)$ $f(s_1) - f^{2nd}(s_2) = O(0.01)$

2nd sheet $s_2 = 3 - 0.01 i$: $f^{2nd}(s_2)$

$f(s)$ has not singularities but $f^{2nd}(s)$ may have when

$$f_l(s) = \frac{1}{2i\rho(s)}$$

Enjoy the rest of the School

Explanation:

- assume $A_\nu = 0$ for $\nu < -m$ ($m > 0$) i.e.

$$f(z) = \sum_{\nu=-\infty}^{\infty} A_\nu (z-a)^\nu = \frac{A_{-m}}{(z-a)^m} + \frac{A_{-m+1}}{(z-a)^{m-1}} + \cdots + \sum_{n=0}^{\infty} A_n (z-a)^n$$

$$A_{-m+1} = \frac{1}{2\pi i} \oint_{C_1} f(z') (z'-a)^{m-2} dz' \neq 0$$

$$A_{-m} = \frac{1}{2\pi i} \oint_{C_1} f(z') (z'-a)^{m-1} dz' \neq 0$$

but

$$A_{-m-1} = \frac{1}{2\pi i} \oint_{C_1} f(z') (z'-a)^m dz' = 0$$

$$A_{-m-2} = \frac{1}{2\pi i} \oint_{C_1} f(z') (z'-a)^{m+1} dz' = 0$$

that is, near point a inside C_1 , $f(z)$ behaves as

$$f(z) \sim A_{-m}/(z-a)^m$$

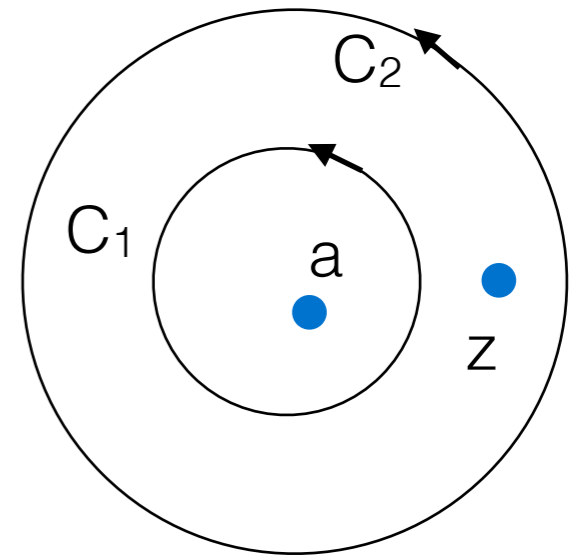

What makes coupling constants real

Example (3)

phase space has $\sqrt{\quad}$ -type singularity: $q \sim \sqrt{E} \sim \sqrt{s - 4m^2}$

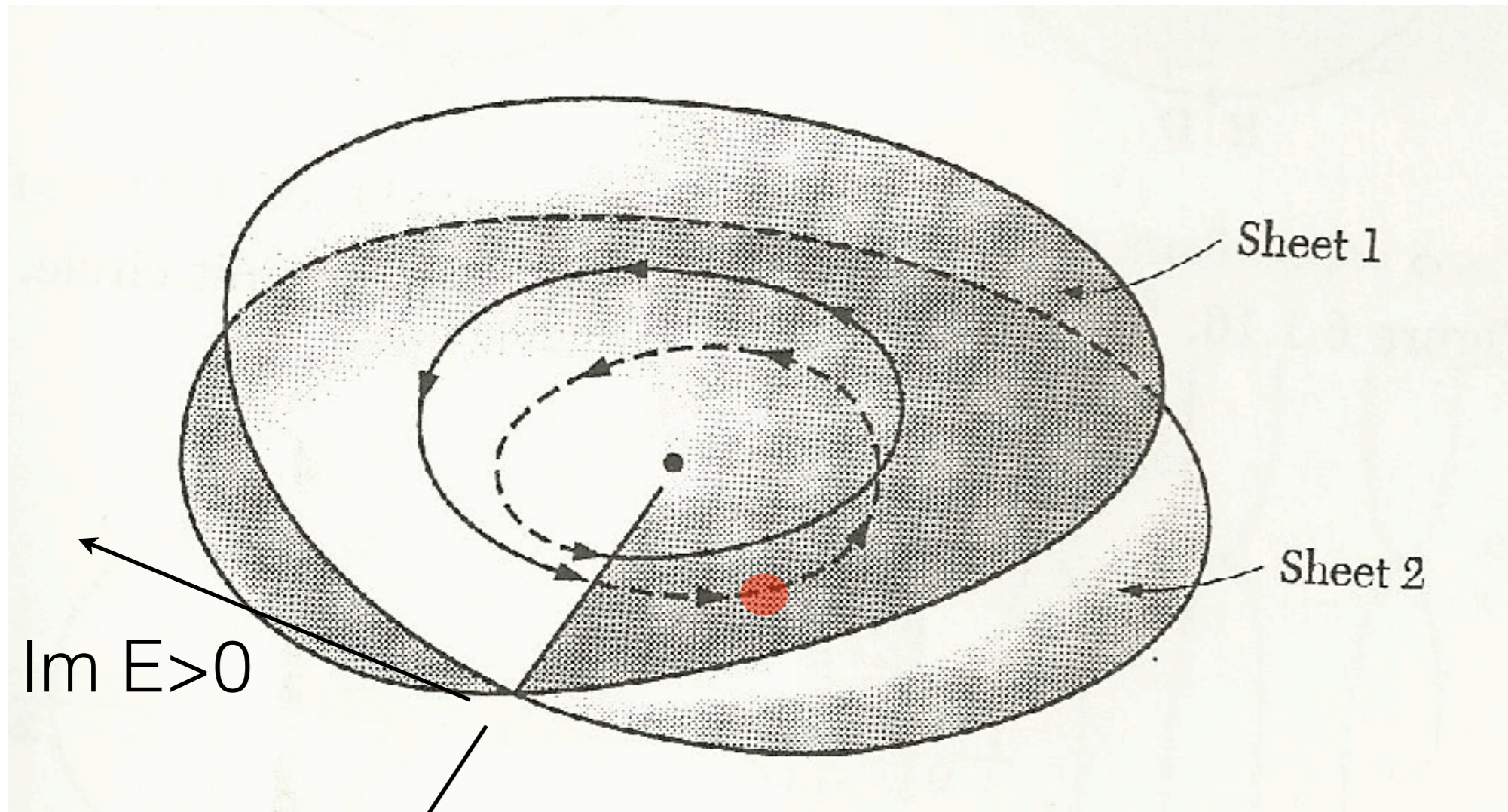

$\text{Im } E > 0$

$\text{Re } E > 0$

$$\Psi(t) \sim e^{-iEt} \sim e^{+(ImE)t}$$

- resonance is a pole for $\text{Im } E < 0$. The $\text{Im } E < 0$ region connected to the real axis lies on the 2nd-sheet

What makes coupling constants real

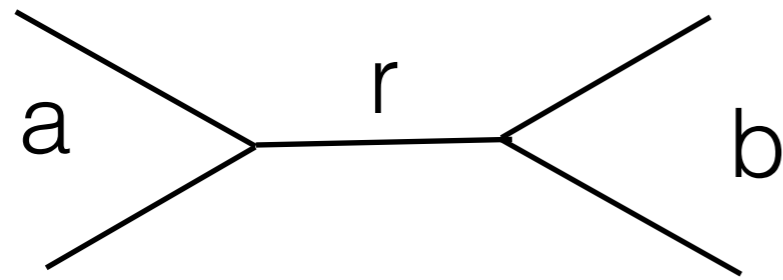

$$T = \frac{\beta}{M^2 - s}$$

$$\beta = g_a g_b$$

$$S_{ab} = \langle b, out | a, in \rangle$$

$$SS^\dagger = I, \quad \sum_c S_{ac} S_{cb}^\dagger = \delta_{ab}$$

S-is can be digitalized using a unitary matrix, U

$$S_{ab} = U_{ac} \hat{S}_{cd} U_{db}^\dagger \quad \hat{S}_{cd} = e^{2i\delta_c} I_{cd} \quad \text{let the resonance be in the 1st element}$$

$$T \sim U_{a1} \frac{\beta}{M^2 - s} U_{b1}^\dagger = U_{a1} \frac{\beta}{M^2 - s} U_{1b}^*$$

$$\text{time-reversal inv.} \rightarrow S_{ab} = S_{ba}$$

$$\rightarrow U_{a1} U_{1b}^* = U_{b1} U_{1a}^*$$

the product of couplings carry no phase so
we can define g_a without a phase

in particular:

- assume $A_\nu = 0$ for $\nu < 0$ i.e.

$$f(z) = \sum_{\nu=-\infty}^{\infty} A_\nu (z-a)^\nu = \sum_{n=0}^{\infty} A_n (z-a)^n$$

$$A_{\nu \leq -1} = \frac{1}{2\pi i} \oint_{C_1} f(z') (z' - a)^{|\nu|-1} dz' = 0 \quad \text{that is } f(z) \text{ is holomorphic inside } C_1$$

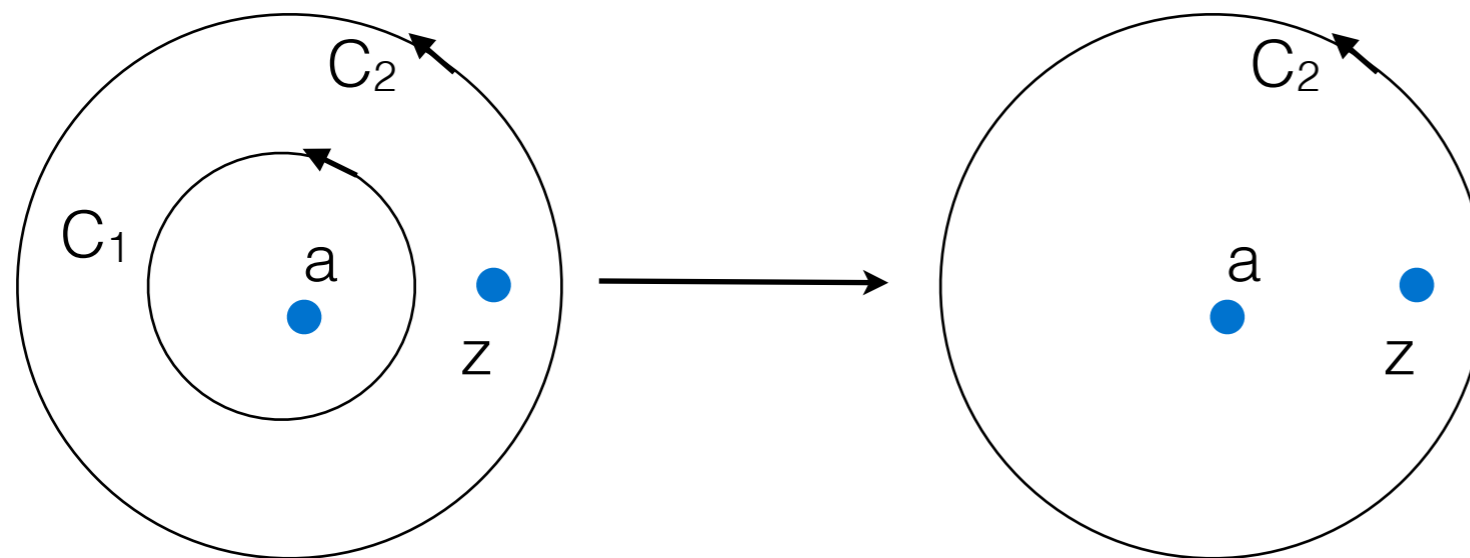

and the Laurent series reduces to Taylor series

$$f(x) = D(x) + iA(x)$$

$$D(x) = \frac{1}{\pi} P.V. \int_{-\infty}^{\infty} dx' \frac{A(x')}{x' - x}$$

$$A(x) = \frac{1}{\pi} P.V. \int_{-\infty}^{\infty} dx' \frac{D(x')}{x' - x}$$

$$\lim_{x \rightarrow 0} \frac{1}{x \mp i\epsilon} = P.V. \frac{1}{z} \pm i\pi\delta(x)$$

$$P.V. \int dx f(x) = \int_{-\epsilon}^{-\epsilon} dx f(x) + \int_{+\epsilon} dx f(x)$$

C. $z \rightarrow \sqrt{z^2 - 1}$ naive definition OK, except that

$$\sqrt{z^2 - 1} \neq \sqrt{z - 1}\sqrt{z + 1}$$

$$\sqrt{z^2 - 1} = \sqrt{r^2 e^{2i\phi} - 1}$$

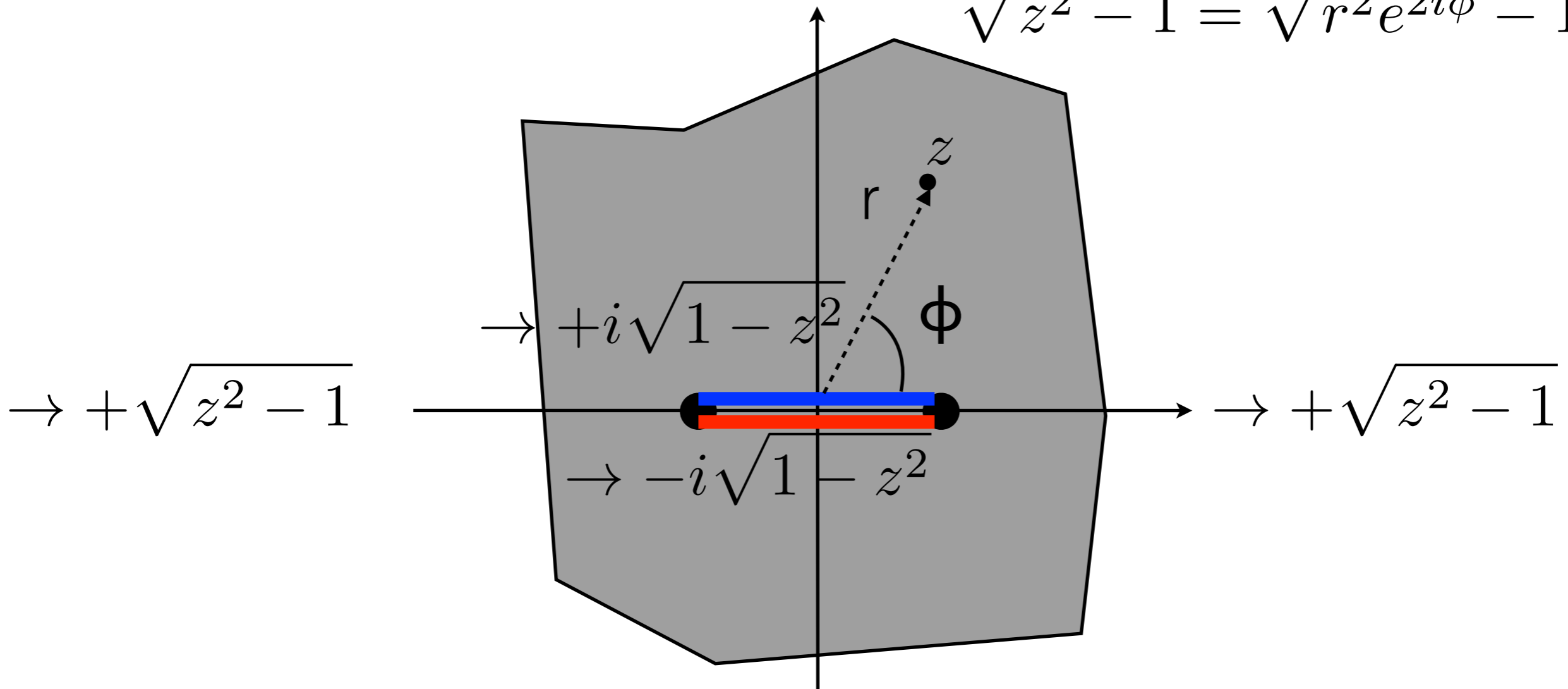

For the following consider:

$$\frac{1}{z-b} = \frac{1}{(z-a) - (b-a)} = \frac{1/(z-a)}{1 - (b-a)/(z-a)} = \sum_{n=0}^{\infty} \frac{(b-a)^n}{(z-a)^{n+1}}$$

the series converges uniformly (can be integrated/differentiated term by term) for all z with $|z-a| > |a-b|$